

INSTRUCTION BOOK

and

PARTS LIST

for

CHRIS-CRAFT MARINE ENGINES

WB - Series

6 Cylinder, 200 Horsepower



BOOK NO. ONE
Reprint 1
Engine Numbers
17, 579 up

Chris-Craft Corporation

Algonac, Michigan

U. S. A.

Cable Address: Chriscraft Algonac

Printed in U. S. A.

WARRANTY

Chris-Craft boats and Chris-Craft parts manufactured by company are warranted to be free from defects in material or workmanship under normal use and service and the company will replace or repair any part thereof, which shall disclose defects within SIX MONTHS, after date of delivery of such boat or part to the original purchaser, and which examination by Company shall determine to be defective; providing that Dealer shall make claim thereon and return said part or parts to Company, transportation prepaid, within 30 days after defect is discovered. The Company does not authorize Dealer to assume for Company any liability in connection with this warranty. Paints, varnishes and chromium plate finishes are believed by the Company to be the best obtainable; however, cannot be guaranteed because of the varying effects which different climates and use conditions have on the same.

This Warranty shall not apply to any Chris-Craft boat or part manufactured by Company, which shall have been altered or repaired outside of the factories of Company.

This Warranty will not apply to any engines, engine accessories or trade accessories not of Company's manufacture which Company may use as these are generally warranted by their respective manufacturers.

This warranty does not cover race boats or racing engines.

Catalogue speeds are estimated or are attained over a certified course at Algonac, Michigan, under favorable conditions and are not guaranteed.

Chris-Craft Corp.

BREAKING IN A NEW ENGINE

The first few hours of operation have a great deal to do with the successful performance of an engine. Engines properly broken in will give much longer satisfactory service.

Before leaving the Chris-Craft factory, your engine has had several hours of "run-in" on the block test and is satisfactory for speeds up to 1500 R. P. M. It should be run for at least 5 hours at not over 1500 R. P. M. and then not over 2000 R. P. M. for the next 5 hours. The engine should not be run at maximum throttle for more than three or five minutes at a time until after the engine has had at least 20 hours.

A good way to tell how the break-in period is progressing, is to idle the engine at 1000 R. P. M., turn off the ignition and note how quickly the engine comes to a stop. You will note that the new engine will stop at once but as the break-in progresses, you will note that it does not stop with such a sudden jerk.

An abnormal rise in temperature on the temperature gauge will indicate that you are running a little too fast.

It is recommended that a pint of regular engine oil be added to each 5 gallons of gasoline for the first few hours of running. Be sure that it is mixed thoroughly in the tank.

During the entire life of the engine, always run the engine at medium speeds for a few minutes to allow the oil to warm up before running at sustained high speeds.

When coming to the dock, after a run, always allow the engine to run at moderate speed for three to five minutes before turning off the ignition. This can be done by slowing down several hundred yards before you get to the dock and coming in slow or letting the engine idle after you have come into the dock. This is to allow the valves to cool down while the water is still circulating in the engine. This will prevent warped valves.

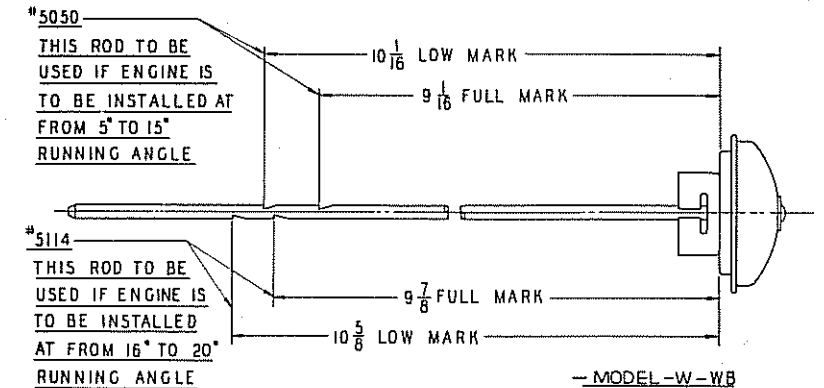

ENGINE LUBRICATION

For engines installed in Chris-Craft boats at the factory, the capacity of the engine lubricating system should be governed by the markings on the oil test rod as the angle of the engine determines the amount of oil to use.

The proper oil test rod markings can be determined from the above illustration after measuring the engine angle in the boat while running.

The engine is run on the test stand with a special rustproof break-in oil. Before shipping, this break-in oil is removed and replaced with SAE #30 Havoline motor oil.

TO CHANGE OIL

The oil should be changed after the first twenty five hours. Thereafter it should be changed every fifty to one hundred hours depending upon the type of service to which the engine is subjected. An engine that is used for short runs needs changing more often than an engine that is run longer periods of time. Long runs permit the oil to get hot enough to evaporate any water that may have accumulated in the crankcase from condensation.

The recommended procedure is to pump the oil out of the crankcase with a suction pump through the oil test rod opening. Most service docks are equipped with special pumps for this purpose.

For the owner who wishes to change the oil himself a piece of copper tubing or a hand suction pump may be used.

When a piece of copper tubing is used, the line going to the oil pressure gauge should be unscrewed from the fitting where it comes out of the block below the ignition coil and the piece of copper tubing should be attached to this fitting. Put the end of this tube in a pail and idle the engine slowly pumping the oil out of the crankcase. Do not speed up the engine. Watch closely and stop the engine as soon as the oil stops running out of the tube. This does not take out sludge below the screen or remove the oil in the reverse gear.

When a hand suction pump is used, the oil is pumped out of the crankcase through the oil test rod opening. By removing the inspection cover on top of the reverse gear housing the oil may be pumped out of this unit also. On reduction gear models there will remain from 1 to 1-1/2 quarts in that unit that cannot be removed. A suitable hand suction pump may be purchased as an accessory from the Chris-Craft Parts and Accessory Department.

RECOMMENDED LUBRICANT

We are primarily interested in seeing that every Chris-Craft is serviced with oil of good character and quality, because the use of such oil means not only dollars in the owner's pocket but smooth engine operation, freedom from trouble, and maximum engine performance. A marine engine works at maximum capacity 90% of its lifetime, whereas in an automobile, the engine rarely, if ever, works at its maximum more than 10% or 15% of its lifetime. Hence, the demands on the oil are far greater in a marine engine.

We recommend the use of a detergent oil with additives to U. S. Military Spec. MIL-L-2104-A (or Supplement #1) or I. C. E. I. "A" or "B" or A. P. I. "MS" or "DG". A straight mineral oil of high quality may be used but we caution that the two types should never be mixed. To do so might cause the formation of sludge. Always replenish with the same make and type of oil that is in the crankcase. If it is necessary to change the make of oil, always drain the crankcase and make a complete change.

EXTRA GALLON OF OIL

The extra gallon of Havoline oil usually furnished with the engine is supplied with the compliments of the Texaco Company. If used for replenishment, be sure to replace it, for it is advisable to have an extra gallon of oil aboard the boat for emergency purposes.

AUTO-LITE ELECTRICAL INSTRUCTIONS

Auto-Lite equipment is guaranteed and serviced by the Electric Auto-Lite Company of Toledo, Ohio. This service is handled through their many Official Service Stations located in all of the more important cities throughout the world. A directory of these Official Service Stations will be furnished any Auto-Lite user by request addressed to the Part and Service Division, the Electric Auto-Lite Company, Toledo, Ohio.

General Care of the Electrical Equipment--

Most important in the care of the electrical equipment is the keeping of all connections not only clean and tight mechanically, but free from all corrosion. Brass and copper connections in a boat operated around salt water are especially subject to corrosion and they should be taken apart two or three times a year, cleaned with fine sandpaper, given a light coating of vaseline and reconnected, being sure they are tight.

Battery terminals should be given special attention and much trouble and annoyance can be avoided if they are periodically taken apart and washed in a strong ammonia or soda solution, given a light coating of vaseline and reassembled, being sure they are tight.

When replacing worn parts only genuine Auto-Lite service parts should be used. While the market affords numerous imitation parts there is no assurance that these are built of the same carefully selected material or are subject to the same exacting inspection as the genuine parts. Therefore, in order to insure yourself the longest possible life of the electrical equipment only genuine Auto-Lite parts should be used.

Generator--

The generator output should never be set above the maximum output as noted on the name plate. All wiring and connections should be tight and the proper size as high resistance in the charging circuit will cause an over voltage that materially shortens the life of lamps or other electrical equipment. The owner should not attempt to repair or adjust the circuit breaker or regulator as these operations should only be handled by an Official Service Station which is equipped with the proper tools and information to correctly repair these units.

Starting Motor--

The starting motor requires no special attention except to see that it is mounted securely and that the Bendix is free from dirt. There should be no voltage loss in the starting circuit and switch as a reduced voltage reduces the cranking power of the motor.

Distributor--

The distributor should be kept free from dirt and properly lubricated. The drain hole in the bottom of the housing should be kept open. Breaker point rubbing blocks are run in at the factory and can be set for proper maximum gap of .022 inch without any run in period. If the points in use show a grayish color, are only slightly pitted and are within .002 inch of the proper maximum gap they need not be replaced or adjusted. However, before adjusting the points they should first be refaced so as to have a smooth flat contact with each other.

The ignition coil is sealed against moisture and needs no attention except to see that the connections are tight.

Lubrication--

Approximately every 50 hours or when the oil is changed the following points should be lubricated with a medium engine oil:

1. The oilers in each end of the generator should be given 3 to 5 drops.

2. The intermediate oiler, if provided, and the commutator end oiler in the starting motor should be given 3 drops.
3. The oiler on the outside of the distributor housing should be given 3 to 5 drops

Every season the distributor cap and rotor should be removed and one drop of light oil put on the breaker arm hinge pin, a light wipe of grease on the cam and a few drops of light oil added to the hole in the top of the distributor drive shaft.

IGNITION

The surfaces of the contact points should be clean and free from rough pittings and grease. After 500 hours running of the boat it may be necessary to re-face these contacts, or to install a new set. The same applies to spark plugs, and when the points become worn and corroded new plugs should be installed. It is important that only the correct type of plug be used in this motor. See page on Specifications and Adjustments.

To set the ignition timing use a timing light. The flywheel is provided with a timing mark on its rim and an ignition timing indicator is positioned over the flywheel ring gear. With the timing light connected to the battery and No. 1 spark plug (flywheel end) and the engine run at idle (see page on Useful Information) set the distributor so that the timing light shows the flywheel timing mark directly in line with the ignition timing indicator.

To set the ignition timing on engines which do not have timing marks, run the boat at its maximum speed and advance the spark until it starts to rattle. At this point speed will drop off, indicating detonation. Then retard it just enough to make the engine run smoothly without any rattle or spark knock. Do not attempt to set the spark with the reverse gear in neutral.

Recheck ignition timing after tightening the distributor to be sure that it is properly set.

For marking engines not previously provided with timing marks see your Chris-Craft Dealer or write

direct to the factory for a quotation on the distributor and instructions necessary.

CARBURETOR

The carburetor is guaranteed and serviced by the Zenith-Detroit Corporation, Foot of Hart Avenue, Detroit, Michigan.

Any service problem may be taken up with them or with the Chris-Craft Service Department.

ADJUSTMENT OF CARBURETOR

Carburetors which have a fixed main jet require no adjustment.

Carburetors with adjustable main jets should be adjusted as follows. Screw the needle valve all the way in, then back it out about two and one-quarter turns. This should make it just a trifle too rich. Run the boat at full throttle and screw the needle valve in until the speed starts to drop off. (Watch the tachometer closely.) Then unscrew it until the engine runs at highest speed. The approximate setting is about two full turns. A too lean mixture will cause pre-ignition and burned valves. It is better to run a little on the rich side.

The idling jet should be set to run the engine at its smoothest.

Carburetors with adjustable main jets can be changed over to fixed main jets quite easily. For further information see your Chris-Craft Dealer or write Chris-Craft Service Department at Algonac, Michigan.

FUEL PUMP

Service on the AC Fuel Pump is available through United Motors Service Branches and authorized AC Service Stations which are prepared with parts and fixtures for repairing all types of pumps.

Any service problem may be taken up with them or with the Chris-Craft Service Department.

CARE OF WATER PUMP

The Water Pump is equipped with a water seal that is automatic in its action. When leaks occur, this seal may be replaced. No lubrication is required.

ADJUSTMENT OF VALVES

It is not possible to put a final adjustment on the valves at the factory that will last the entire season. After a few hours running the boat should be taken back to the dealer and the valves readjusted. Loss of engine speed and increase in gasoline consumption is the first indication for the need for grinding valves. An engine that is driven at sustained high speeds will need valve grinding much oftener than one that is used at normal speeds.

REVERSE GEAR

Important Recommendation --

It is not recommended that the boat be run at the dock with the reverse gear in the neutral position (except on engines equipped with Chris-Craft Chris-O-Matic clutch controls). Space here will not permit a detailed diagram on the construction and operation of a reverse gear but let it suffice to say that when the reverse gear is in the neutral position it compares to an automobile when the clutch pedal is pushed to the floor.

If you wish to warm up the engine at the dock put the nose of the boat against the dock and put the lever in the go-ahead position and run the engine slowly.

If you are familiar with the reverse operation of the gear you will know that in reversing, the reverse band is clamped firmly to the clutch drum. Therefore, it is important that the reverse lever be pulled back firmly so that the band will not slip on the drum. Pull the lever back and hold it there as long as you want to reverse and control the speed by the throttle and not by allowing the band to slip. It is not intended that the reverse gear be used as a brake.

Adjustments--

It is necessary that your reverse gear be properly adjusted before you operate it. The forward drive is obtained by means of a multiple disc clutch. The locking or clamping of these discs is brought about by the pressure produced by the outward movement of the fingers when the operating lever is thrown into the forward position. On the forward drive the whole reverse gear is locked together as a solid coupling. Unless the pressure on these discs is great enough to lock the whole reverse gear together under full load, the clutch will slip and heat.

The reverse drive is obtained by clamping the brake band around the outside drum or case which carries the pinion gears. The reverse motion is then obtained by driving through the gears. Unless this band is clamped tight enough to keep this gear cage from revolving, it will slip in the reverse position.

In neutral position, both the discs and brake band are free and the gears run idle.

Adjustment for the Forward Drive --

(See Reverse Gear illustration at back of book)

If the gear slips in the forward drive back out the lock screw No. 76 until the end of it is clear of the hole in the pressure disc No. 11. Then turn the adjusting finger collar No. 28 to the right until the lock screw No. 76 is opposite one of the holes in the pressure disc No. 11.

Then tighten up the lock screw No. 76 and be sure that end of the screw enters the hole in the pressure disc No. 11. Repeat this procedure until the reverse gear holds on the forward drive. An adjustment of one or two holes is usually sufficient.

Adjustment for Reverse Drive --

with Toggle Clamping Mechanism

In the reverse position the brake band is supposed to grip and hold the gear cage or drum from turning. If this drum slips, it is necessary to tighten the adjustment of the brake band, which adjustment is made as follows:

Loosen the locknut No. 429 on the inside of the

upright lug at the top of the brake band to the amount you think the brake band needs adjusting. Then tighten the adjusting nut No. 431 on the outside of this lug until it is again tight against this lug. Repeat until the brake band grips the gear cage and keeps it from revolving.

The adjustment should be tight enough so that a decided snap is felt when the lever is thrown into the reverse position.

ENGINE ALIGNMENT

Many cases of excessive vibration, reverse or reduction gear noise, and loss of revolutions, are caused by engine misalignment. This alignment is checked by disconnecting the two halves of the shaft coupling just aft of the reverse or reduction gear. The faces of these flanges must be within .003 parallel in all directions. The engine is mounted on taper shims to facilitate this adjustment. For further information refer to the paragraph on this subject in the Boat Owner's Manual.

ENGINE KNOCKS AND LOSS OF REVOLUTION

A sudden and otherwise inexplicable drop in revolutions, a new and disturbing period of vibration, and a sudden loss of speed without other apparent cause, are usually definite symptoms of propeller wheel disorders even though the propeller wheel itself looks to be undamaged.

Never attempt to judge the condition of a propeller from its appearance. Though undamaged to the naked eye it may show startling pitch discrepancies when subjected to careful measurements with proper instruments. It is not necessary to run aground or become entangled with drift in order to throw a propeller out of pitch. Especially in the case of high-speed, high-power runabouts, loss of pitch will occur in the course of normal operation. A sudden turn at high speed, or bucking a heavy sea is often sufficient to submit one or more of the blades to a sudden shock or load beyond their normal ability to withstand, resulting in a propeller which, though not perceptibly

damaged, is sufficiently "out of pitch" to account for several hundred lost R. P. M. on the tachometer or set up a serious vibration period.

Engine knocks are usually caused by faulty lubrication, and if you take proper care of the oiling of your motor you will probably never hear a knock.

Knocks which start suddenly and rapidly get louder are dangerous. Stop motor and investigate oil supply and water circulation, including water intake. Do not run motor with a loose bearing.

Knocks which begin faintly and increase slowly if at all are not immediately dangerous, but should be investigated by a mechanic or your Chris-Craft dealer as soon as possible.

If you are caught off shore with a burned out rod bearing due to lack of oil in the crankcase and must run the motor in order to get to land, removing spark plug in the bad cylinder is your best chance. Run slowly.

MISFIRING

The most frequent causes of misfiring are as follows: (It is entirely unlikely that you will be troubled with any of these things, but it is well to know what to do in case of emergency): 1--Dirty or cracked plugs; remedy--install new ones or clean them. 2--Intermittent electric leak somewhere in the wiring; remedy trace and insulate. 3--Stuck valve, or broken valve spring. Remove valve cover plate and inspect valve mechanism; remedy--new spring or grinding valves, or both. 4--Valve tappets too close. At high speed close - set tappets will ride the cams, prevent the valves from closing, and thus cause misfiring; remedy adjust tappets. See page on Specifications & Adjustments for clearances. 5--Breaker points out of adjustment; when a motor misses at low speeds only, inspect breaker points first. 6--Water in one or more cylinders due to blown gaskets or crack in water jacket. 7--Blown or leaking gaskets, either in manifold or cylinder head. 8--Loose spark plugs. 9--Too high oil level, causing sooty plugs.

IMPORTANT NOTICE

Form the habit of watching the oil pressure gauge. This gauge is sometimes called the "watch dog" of the engine. Advance notice of serious trouble is nearly always given by the oil gauge.

If the pressure suddenly drops off, stop the engine immediately and do not run it until the trouble is located and remedied. See if there is plenty of oil in the crankcase. An oil line may be broken or the gauge broken--Try a new gauge first. If the oil pressure suddenly goes too high look for a plugged oil line or the relief valve may be stuck. If the oil pressure falls off gradually, the oil may be worn out or diluted with gasoline. If you have plenty of pressure when the engine is cold and drops off when hot you may not be using an oil suitable for marine use. See Page 3 for Recommended Lubricant.

If you have very low pressure when the engine is cold and near normal when hot, or if the pressure drops below recommendation when running hard (see section on Useful Information) check for a clogged oil screen. This screen is accessible through the hand-hole cover on the side of the oil pan and should be cleaned once every season.

Do not change the oil pressure regulating valve to compensate for sudden changes in oil pressure or to compensate for the incorrect grade of oil.

USEFUL INFORMATION

Engine

Type--L-Head, vertical

Cylinders--6

Bore--4-1/4"

Stroke--4-3/4"

Brake Horsepower-200 at 3,200 RPM

Piston Displacement--404.3 cu. in.

Compression Ratio--6.48:1

Weight--WB 1,260 lbs.

WBS, WBR2 & WBR 1,350 lbs.

Electrical System

Battery--6 volt

Generator Charging Rate--14 to 19 Amps. Max.

Generator Cuts in at 800 Engine RPM

Oiling System

5 pounds (minimum)-idling speed

20 to 35 pounds - maximum speed - hot.

Recommended Idling Speed

500 RPM

TO DRAIN THE WATER SYSTEM

There are five drain plugs to be removed. One in the exhaust manifold at the end, one on the bottom of the water pump, one on the bottom of the oil cooler, one in the oil cooler support bracket which is attached to the side of the block, and one in the intake manifold.

USE ONLY CHRIS-CRAFT PARTS

Genuine Chris-Craft parts are identified by this label:



or the name *Chris Craft* cast in the casting.

SPECIFICATIONS AND ADJUSTMENTS

Valve Clearance--Engine Cold

Exhaust Valve--.018

Intake Valve--.012

Valve Seat-

Exhaust-Diam. 1-25/32"-Face 3/32"-Angle 30°

Intake-Diam. 1-15/16"-Face 7/64"-Angle 30°

Valve Guide Clearance-

Exhaust-.0025 to .003

Intake-.0025 to .003

Tappet Guide Clearance-.00075 to .001

Idler Shaft Clearance-.001 to .0015

Idler Gear back lash to Camshaft-.001 to .002

Camshaft Bearing Clearance-.0015 to .0025

Camshaft Gear back lash to Crankshaft .000 to .001

Crankshaft Main Brng. Clearance-.001 to .0035

Crankshaft Thrust Clearance-.003 to .004

Conn. Rod Brng. Clearance-.001 to .0035

Conn. Rod Side Clearance-.008 to .015

Accessory Shaft Clearance-.0015 to .0025

Accessory Gear back lash to Idler Gear .002 to .004

Accessory Shaft End Thrust-.002 to .003

Oil Pump Gear back lash to Camshaft-.008 to .015

Dist. Drive Gear back lash to Dist. Driven Gear-.003 to .008

Piston Clearance (at skirt) .006 to .0062

Piston Pin Clearance in Piston - Hand Push Fit

Piston Ring Gap-.015 to .020

Piston Ring Side Clearance-

Comp. Rings .0025 to .0035

Oil Rings .002 to .003

Distributor Point Gap-.022

Spark Plug - J8J Red Line Gap-.028

Firing Order-

Standard Rotation - 1-5-3-6-2-4

Opposite Rotation - 1-4-2-6-3-5

PARTS LIST
CHRIS-CRAFT MARINE MOTOR

Model WB -- All Models

See Your Chris-Craft Dealer or Write Direct to
Factory for Prices

Part No.	No. Reqd.	Name
CYLINDER AND CRANKCASE AND STRIPPED ENGINE ASSEMBLY		
H115429	1	Cylinder and Crankcase with Valve Guides, Camshaft Bearings and Idler Gear Bushing
13969	1	Stripped Engine Assy. with Valves, Pistons, Crankshaft, Camshaft and Connecting Rods, Std. Rot. - WB
13970	1	Stripped Engine Assy. with Valves, Pistons, Crankshaft, Camshaft and Connecting Rods - Opp. Rot. - WBO
H15739	1	Timing Gear Oil Nozzle Assy.
H15133	1	Timing Gear Oil Nozzle Gasket
H4243	2	Timing Gear Oil Nozzle Screw (Special)
H4879	2	Cylinder Side Hole Cover Plate
H22564	2	Cylinder Side Hole Cover Plate Gasket
3202	2	Expansion Plug - 5/8"
H14435	2	Expansion Plug - 15/16"
H3688	1	Expansion Plug - 1-1/8"
H59	1	Pipe Plug - 1/8"
H22158	1	Pipe Plug - 3/8"
H11108	4	Pipe Plug - 3/4"
H11129	4	Pipe Plug - 1"
H60	3	Pipe Plug -1-1/4"
H3560	6	Pipe Plug -1-1/2"
H3686	1	Pipe Plug -2-1/4"

Be Sure To Give Engine Number When Ordering Parts

Part No.	No. Reqd.	Name
MAIN BEARINGS		
13964	1	Set Main Bearings-Std. consisting of: 2-21572 Front Main Bearing Upper & Lower 2-21573B Center Main Bearing Upper & Lower 2-21584B Rear Main Bearing Upper & Lower 8-21583B Intermediate Main Bearing Upper & Lower
13965	1	Set Main Bearings- .002 U. S.
13966	1	Set Main Bearings- .010 U. S.
13967	1	Set Main Bearings- .020 U. S.
H19680	4	Main Bearing Thrust Washer
H4765	4	Main Bearing Thrust Washer Pin (Thrust Washers not Included in Sets)
H20097	8	Main Bearing Cap Screw-Center & Rear
H20096	10	Main Bearing Cap Screw-Front & Intermediate
GASKET SET		
13968	1	Complete Set of Gaskets
CONNECTING ROD		
H21577	6	Conn. Rod Assy. (With Bearing)
13984	12	Conn. Rod Bearings-Std. (21576-B)
13985	12	Conn. Rod Bearings - .002 U. S.
13986	12	Conn. Rod Bearings - .010 U. S.
13987	12	Conn. Rod Bearings - .020 U. S.
H21055	12	Conn. Rod Bolt
H21056	12	Conn. Rod Nut
H115116	6	Conn. Rod Piston Pin Bushing
PISTONS AND RINGS		
14578	6	Pistons Std. Size (21339)

Be Sure To Give Engine Number When Ordering Parts

Part No.	No. Reqd.	Name
PISTONS AND RINGS (Cont'd)		
14579	6	Pistons -.010 O.S.
14580	6	Pistons -.020 O.S.
14581	6	Pistons -.030 O.S.
14982	1	Set Piston Rings - Std. (4374)
14983	1	Set Piston Rings .020 O.S.
14984	1	Set Piston Rings .030 O.S.
13981	6	Piston Pin Std. (21129-B)
13982	6	Piston Pin .003 O.S.
13983	6	Piston Pin .005 O.S.
H21131	12	Piston Pin Retainer
CRANKSHAFT		
H20541	1	Crankshaft
H18039	1	Crankshaft Gear - Std. Rot.
H18829	1	Crankshaft Gear - Opp. Rot.
H1247	1	Crankshaft Gear Key
VALVES		
H21023	6	Intake Valve
H115011	6	Exhaust Valve
H115010	12	Valve Spring
H20712	6	Int. Valve Guide
H18004	6	Int. Valve Spring Seat
H76011	12	Int. Valve Spring Seat Lock
H115014	6	Exh. Valve Guide
H115012	6	Exh. Valve Spring Seat
H115013	6	Exh. Valve Rotor Cap
H20022	12	Exh. Valve Rotor Cap Key
H18006	1	Valve Cover - Plain
5192	1	Valve Cover - with fume tube
H18005	2	Valve Cover Gasket - Cork
H4384	4	Valve Cover Screw
H14311	4	Valve Cover Screw Washer

Be Sure To Give Engine Number When Ordering Parts

Part No.	No. Reqd.	Name
VALVE TAPPET		
H21088	12	Valve Tappet Assembly
H2185	12	Valve Tappet Screw
H2186	12	Valve Tappet Screw Lock Nut
H115015	1	Valve Tappet Guide Cluster - Front
H115016	1	Valve Tappet Guide Cluster - Rear
H2210	4	Valve Tappet Guide Cluster Dowel
CYLINDER HEAD		
5186	1	Cylinder Head
H115209	1	Cylinder Head Gasket
H3688	3	Cylinder Head Expansion Plug 1-1/8"
5208	30	Cylinder Head Studs
3622	30	Cylinder Head Stud Nut 1/2" x 20
3374	30	Cylinder Head Stud Washer
LIFTING EYE		
1784	1	Lifting Eye
	1	Lifting Eye Lockwasher 5/8"
SUPPORT BRACKETS		
2090	1	Engine Front Support
2180	1	Engine Front Support Gasket
5122	2	Dowel Capscrews
1803	2	Engine Front Support Keelson Bracket - Direct
2363	2	Engine Front Support Keelson Bracket - Reduction
1560	2	Engine Front Support Rubber Mounting
2088	1	Engine Rear Support
2171	1	Engine Rear Support Gasket
14013	2	Engine Rear Support Dowel Bushing (2153)
2201	2	Engine Rear Support Keelson Bracket

Be Sure To Give Engine Number When Ordering Parts

Part No.	No. Reqd.	Name
----------	-----------	------

SUPPORT BRACKETS (Cont'd)

1430	4	Engine Rear Support Rubber Mountings
2147	2	Engine Rear Support Stud - Long
14011	2	Engine Rear Support Stud - Short (2145)
5168	1	Ignition Timing Indicator

CAMSHAFT

H115064	1	Camshaft-Std. Rot.
H115065	1	Camshaft-Opp. Rot.
H18049	1	Camshaft Gear - Std. Rot.
H18828	1	Camshaft Gear - Opp. Rot.
H1247	1	Camshaft Gear Key
H202690	1	Camshaft Gear Nut
2277	1	Camshaft Gear Thrust Adj. Screw (Short)
H2048	1	Camshaft Gear Thrust Adj. Screw Nut
H21057	2	Camshaft Bearing - Front & Rear
H21058	2	Camshaft Bearing - Center
H4342	1	Camshaft Bearing Thrust Washer
14960	1	Camshaft Thrust Plunger (14209-A)

IDLER GEAR

H20056	1	Idler Gear - Std. Rot.
H20061	1	Idler Gear - Opp. Rot.
H20058	1	Idler Shaft - Std. Rot. With Plunger
H20060	1	Idler Shaft - Opp. Rot. With Plunger
H20057	1	Idler Shaft Bushing
H17917	1	Idler Gear Thrust Washer
2278	1	Idler Gear Thrust Adj. Screw
H2048	1	Idler Gear Thrust Adj. Screw Nut
H920	1	Idler Gear Key
14960	1	Idler Shaft Thrust Plunger (14209-A)

Be Sure To Give Engine Number When Ordering Parts

Part No.	No. Reqd.	Name
----------	-----------	------

ACCESSORY DRIVE

H19947	1	Acc. Drive Housing - Outside
H18367	1	Acc. Drive Shaft Sleeve
H15149	2	Acc. Drive Housing Gasket
H115280	1	Acc. Drive Bushing
H15195	1	Acc. Drive Gear - Std. Rot.
H16444	1	Acc. Drive Gear - Opp. Rot.
H1247	1	Acc. Drive Gear Key (Woodruff #15)
H20182	1	Acc. Drive Shaft - Std. Rot.
H20183	1	Acc. Drive Shaft - Opp. Rot.
H4342	2	Acc. Drive Thrust Washer
H15096	1	Acc. Drive Dist. Drive Gear Std. Rot.
14634	1	Acc. Drive Dist. Drive Gear Opp. Rot. (19076)
H2165	1	Acc. Drive Dist. Drive Gear - Key
H11316	2	Acc. Drive Shaft Nut
H11697	1	Acc. Drive Shaft Nut Lock Washer
H4068	2	Acc. Drive Attaching Screw
H312	2	Acc. Drive Attaching Lock Washer
H3632	1	Acc. Drive Expansion Plug - Brass 1-3/4"

FLYWHEEL

2212	1	Flywheel with Ring Gear - Std. Rot.
2213	1	Flywheel with Ring Gear - Opp. Rot.
1573	1	Flywheel Ring Gear - Std. Rot.
1574	1	Flywheel Ring Gear - Opp. Rot.
14016	1	Flywheel Cover
H7104	4	Flywheel Bolt
5116	2	Crankshaft Dowel
2120	4	Flywheel Bolt Sleeve Nut
2304	1	Flywheel Pulley
1875	1	Starting Crank

Be Sure To Give Engine Number When Ordering Parts

Part No.	No. Reqd.	Name
OIL PAN AND OIL STRAINER		
5038	1	Oil Pan
2178	2	Oil Pan Gaskets
5046	1	Oil Strainer Assy.
2309	1	Oil Strainer To Pump Flexible Tube Assy.
4248	1	Oil Strainer Tube Elbow Fitting 5/8" T x 1/2" MPT
1737	1	Oil Pan Inspection Plate
1610	1	Oil Pan Inspection Plate Gasket
14012	2	Oil Pan to Block Studs
OIL FILLER		
5048	1	Oil Filler
1915	1	Oil Filler to Oil Pan Gasket
5156	1	Test Rod Assy. - Unmarked - (See Page 2 for Markings)
OIL PUMP		
H115165	1	Oil Pump Assy. - Std. Rot.
H115166	1	Oil Pump Assy. - Opp. Rot.
OIL LINES		
14638	1	Main Bearing Oil Harness (19171-BS)
H4120	8	Oil Harness Union
H4121	3	Oil Harness Union Nut-End
H11038	5	Oil Harness Union Nut-Center
14959	8	Oil Harness Ferrule (4122-A)
H2396	2	Oil Harness to Cylinder Block Union
H18123	1	Oil Pump to Cylinder Block Line 1/2" x 11 - 3/16"
H2397	1	Oil Pump to Oil Line Union Nut
H4259	1	Oil Pump to Cylinder Block Union
H4260	1	Oil Line to Cylinder Block Union Nut
H4261	1	Oil Line to Cylinder Block Union Nut Ferrule

Be Sure To Give Engine Number When Ordering Parts

Part No.	No. Reqd.	Name
OIL LINES (Cont'd)		
H18097	1	Oil Line Assy. - Oil Pump to Oil Pump Drive Gears
H1659	1	Oil Line Elbow
OIL PRESSURE REGULATOR		
14017	1	Oil Press. Reg. Body (2168)
2193	1	Oil Press. Reg. Body Gasket
H8574	1	Oil Press. Reg. Cap Nut
H8573	1	Oil Press. Reg. Lock Nut
H8575	2	Oil Press. Reg. Lock Nut Gasket
H8572	1	Oil Press. Reg. Valve Adj. Plug
H15243	1	Oil Press. Reg. Plunger
H8571	1	Oil Press. Reg. Plunger Spring
MANIFOLDS		
5244	1	Exhaust Manifold
H3688	7	Exhaust Manifold Expansion Plug 1-1/8"
2156	1	Exhaust Manifold Gasket
5188	6	Exhaust Manifold Stud - Long
14011	6	Exhaust Manifold Stud - Short (2145)
3286	12	Exhaust Manifold Stud Nut 1/2" - 20
2141	1	Exhaust Manifold Water Inlet Flange
2192	1	Exhaust Manifold Water Inlet Flange Gasket
5058	1	Exhaust Manifold End Cover
5060	1	Exhaust Manifold End Gasket
5180	1	Intake Manifold
2154	1	Intake Manifold Gasket - Center
5242	2	Intake Manifold Gasket - End
3194	1	Pipe Plug 1/4" Hex. Hd. - Brass 1pc. Hose-Head to Manifold 1-1/4" I. D. 3 ply x 5"
12594	2	Hose Clamps

Be Sure To Give Engine Number When Ordering Parts

Part No.	No. Reqd.	Name
EXHAUST ELBOWS		
4028	1	Exhaust Elbow Assy. - Vertical
3904	1	Exhaust Elbow Assy. Horiz. to Port
4024	1	Exhaust Elbow Assy. Horiz. to Stbd.
3334	4	Capscrews 3/8" 16 x 1-1/8"
H342	4	Lockwasher 3/8"
2181	1	Exhaust Elbow Gasket
Note: Exhaust Elbow Assemblies may be ordered in either brass or cast iron.		
2139	1	Exhaust Pipe Fitting for 2-1/2" Std. Iron Pipe
	2	Capscrews - 3/8" 16 x 2"
H682	2	Capscrews - 3/8" 16 x 2-3/4"
H342	4	Lockwashers 3/8"
2181	1	Exhaust Pipe Fitting Gasket
CARBURETOR		
4372	2	Carburetor Assy. (Zentih Outline 11715)
1788	2	Carburetor Gasket
5254	4	Carburetor Stud
H4732	4	Carburetor Stud Lock Washer 7/16" S. A. E. Std.
3276	4	Carburetor Stud Nut 7/16" - 20
1557	2	Carburetor Flame Arrestor Zenith B 175-13
14101	1	Carburetor Repair Kit
5232	1	Throttle Control Shaft Assy. Consisting of:
	1	5230 Shaft
	2	13196 Ball Joints
FUEL PUMP		
1578	1	Fuel Pump Assy. AC 5594230
1462	1	Fuel Pump Gasket
14102	1	Fuel Pump Repair Kit A. C. 5593777

Be Sure To Give Engine Number When Ordering Parts

Part No.	No. Reqd.	Name
FUEL PUMP (Cont'd)		
5246	1	Gas Line Fuel Pump to Tee
5248	1	Gas Line Tee to Front. Carb.
5250	1	Gas Line Tee to Rear Carb.
	1	Gas Line Tee 5/16" Tube (2305)
13760	3	Connectors 5/16" T x 1/4" M. P. T.
ELECTRICAL EQUIPMENT		
1594	1	Generator Auto Lite GEO 4801 Std. Rot.
1595	1	Generator Auto Lite GEO 4802 Opp. Rot.
1596	1pr.	Generator Belt
2305	1	Generator Pulley
2106	1	Generator Bracket
1802	1	Generator Shaft Spacer Washer
1581	1	Starting Motor Auto Lite ML 4345 Std. Rot.
1582	1	Starting Motor Auto Lite ML 4346 Opp. Rot.
4348	1	Distributor and Gear Assembly Std. Rot. Auto Lite I. A. Y. 4009
4350	1	Distributor and Gear Assembly Opp. Rot. Auto Lite I. A. Y. 4009
H15097	1	Distributor Driven Gear-Std. Rot.
14635	1	Distributor Driven Gear-Opp. Rot. (19077)
3416	1	Distributor Driven Gear Pin
1530	1	Tachometer Fitting
1410	1	Tach. Fitting Packing Gland
3474	3	Tach. Fitting Packing Gland Washer
1469	1	Ignition Coil - Auto Lite CR - 6001
14118	1	Ignition Coil Bracket (2095)
5228	1	Ignition Cable - Dist. to Coil - High Tension
1665	1	Ignition Cable - Dist. to Coil - Low Tension
1651	1	Ignition Cable - Spark Plug Cyl. #1
14021	2	Ignition Cable - Spark Plug Cyl. #2 -3
1650	3	Ignition Cable - Spark Plug Cyl. #4-5-6

Be Sure To Give Engine Number When Ordering Parts

Part No.	No. Reqd.	Name
----------	-----------	------

ELECTRICAL EQUIPMENT (Cont'd)

1470	6	Spark Plug J-8-J Red Line
5126	1	Ignition Cable Bracket (Small)
5128	1	Ignition Cable Bracket (Large)
1869	6	Ignition Wire Grommet

OIL COOLER - RV - 25

1588	1	Oil Cooler - Without Base
3192	2	Oil Cooler Gasket
2271	1	Oil Cooler Base Bracket
4942	1	Base Bracket Gasket
2210	1	Oil Cooler Center Stud
3402	1	Center Stud Copper Gasket
3364	1	Center Stud Nut - 3/8" - 24" Acorn
2342	1	Oil Line - 1/2" x 9-7/16"
2343	1	Oil Line - 1/2" x 8-3/16"
13777	4	Oil Line Connectors
2327	1	Water Tube - Oil Cooler to Exhaust Manifold
	2pc.	Hose 1-1/4" I. D. 3 ply x 3-1/2"
12594	4	Hose Clamps

WATER PUMP

4232	1	Water Pump Assembly
2328	1	Water Pump to Oil Cooler Connector
14089	2pc.	Hose 1-1/4" I. D. 3 ply x 1-5/8"
12594	4	Hose Clamps
	3	Street Elbow - 1" 90° Brnz.
2334	1	Hose Nipple - 1" x 1-1/2" Brnz.
2188	1	Hose Nipple - 1" x 2" Brnz.

Be Sure To Give Engine Number When Ordering Parts

Part No.	No. Reqd.	Name
----------	-----------	------

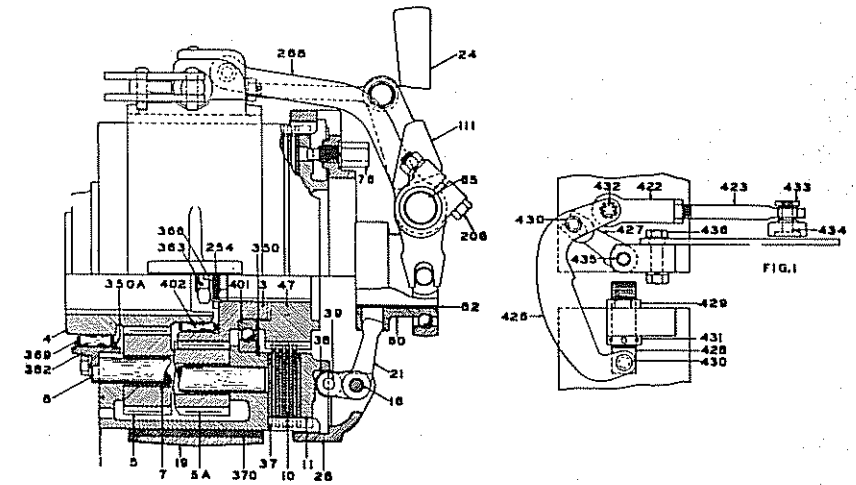
REVERSE GEAR
REVERSE GEAR ASSEMBLY 4XE5-90

19410	1	Gear Cage or Drum	(HJ-1012B)
19193	1	Propeller Gear	(4XE3-3)
19194	1	Engine Gear	(4XE3-4)
1636	1	Engine Gear Screw	
3480	1	Engine Gear Key	(Woodruff #TX)
19180	3	Pinion Gear-Long	(4XE-5A)
19181	3	Pinion Gear-Short	(4XE-5B)
19135	12	Pinion Bushing	(3XE-7A)
19227	6	Pinion Stud	(45X-8A)
19195	4	Friction Disc-Inside	(4XE3-10)
19411	5	Friction Disc-Outside	(HJ-1108)
19196	1	Pressure Plate	(4XE3-11A)
19177	3	Clutch Finger Pin	(4X-16)
19183	1	Brake Band-Lined	(4XE-19A)
19190	2	Lining Only	(4XE-370B)
19184	3	Finger Assy.	(4XE-21)
19197	1	Adjusting Collar	(4XE3-28)
19199	1	Disc. Driver	(4XE3-47)

Be Sure To Give Engine Number When Ordering Parts

Part No.	No. Reqd.	Name
----------	-----------	------

REVERSE GEAR ASSEMBLY 4XE5-90 (Cont'd)

19203	1	Operating Sleeve - With Ball Bearing Throwout Collar (4XE3-60)
19215	2	Yoke Shaft (5X-65A)
13801	3	Yoke Shaft Key (Woodruff #127)
19204	1	Adjusting Lock Screw (4XE3-76)
19205	1	Operating Sleeve Bushing (4XE3-82)
19187	1	Throwout Yoke (4XE-111)
19188	2	Throwout Yoke Screw (4XE-206A)
19154	1	Propeller Gear Washer (3XE-254)
19189	1	Brake Band Support (4XE-288B)
19116	1	Propeller Gear Nut (2XE-363)
19159	1	Propeller Gear Washer (3XE-366)
19211	1	Gear Cage Roller Bearing (4XE3-369)
19210	2	Bearing Retaining Rings (4XE3-350)
19412	1	Roller Bearing Race (4XE4-382)
19217	1	Gear Cage Ball Bearing (5XE-401)
19216	1	Bearing Retaining Ring (5XE-350)
19214	1	Clutch Hand Lever (5X-24)
19213	1	Pilot Roller Bearing (4XE3-402)
19163	1	Toggle Link-End (3XE-422)
19165	1	Toggle Link (3XE-423A)
19166	2	Toggle Lever-Long (3XE-426)
19167	1	Toggle Lever-Short (3XE-427A)
19169	1	Toggle Adjusting Bolt (3XE-428)
19170	2	Adj. Bolt Locknut (3XE-429)
19171	2	Toggle Pin-Long (3XE-430)
19172	1	Toggle Ball Joint (3XE-432)
19173	1	Yoke Ball Joint (3XE-433)
19174	1	Yoke Ball Joint Screw (3XE-434)
19175	1	Toggle Pin-Short (3XE-435)
19176	1	Brake Band Brace Screw (3XE-436)
2242	2	Brake Band Support Pin
2243	2	Brake Band Support Block
2232	1	Reverse Gear Top Cover
2254	1	Top Cover Gasket
2255	1	Reverse Gear Housing Gasket

Be Sure To Give Engine Number When Ordering Parts

Part No.	No. Reqd.	Name
----------	-----------	------

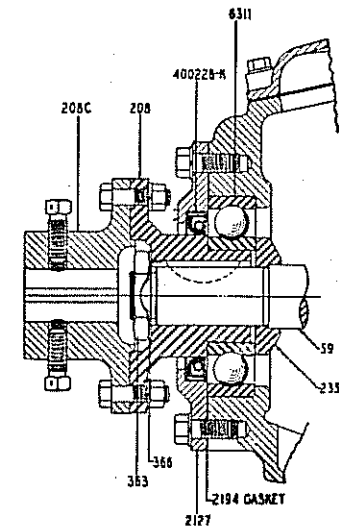

REVERSE GEAR REAR END
(Direct Drive)

REVERSE GEAR ASSEMBLY 4XE5-90 (Cont'd)

1406	4	Stud-Housing to Rear Cover
3428	2	Yoke Shaft Oil Seals
FOLLOWING PARTS USED WITH DIRECT DRIVE ENGINES		
19419	1	Reverse Gear Assembly (4XE5-90 Spec. Z-6179)
19201	1	Stub Shaft (4XE3-59A)
19151	1	Shaft Coupling-Engine Half (3XE-208)
*1739	1	Shaft Coupling-Shaft Half (Give Shaft Size)
19153	1	Thrust Washer (3XE-235A)
19384	1	Shaft Coupling Nut (RDC-363)
19385	1	Shaft Coupling Washer (RDC-366)
14006	1	Rear Oil Seal Retainer
14024	1	Retainer Gasket

Be Sure To Give Engine Number When Ordering Parts

Part No.	No. Reqd.	Name
FOLLOWING PARTS USED WITH DIRECT DRIVE ENGINES (Cont'd)		
2231	1	Reverse Gear Housing
3154	1	Rear Oil Seal
3152	1	Rear Ball Bearing (SKF 6311)
FOLLOWING PARTS USED WITH 1-1/2:1 REDUCTION DRIVE - WBS		
19420	1	Reverse Gear Assembly (4XE5-90 Spec. Z-6183)
19202	1	Stub Shaft (4XE3-59C)
2250	1	Reverse Gear Housing
19274	1	Thrust Washer (RB15-235)
FOLLOWING PARTS USED WITH 2:1 REDUCTION DRIVE - WBR2		
19421	1	Reverse Gear Assembly (4XE5-90 Spec. Z-6285)
19200	1	Stub Shaft (4XE3-59)
2468	1	Reverse Gear Housing
19316	1	Thrust Washer (RC20-235B)
FOLLOWING PARTS USED WITH 2-1/2:1 REDUCTION DRIVE - WBR		
19422	1	Reverse Gear Assembly (4XE5-90 Spec. Z-6184)
19413	1	Stub Shaft (4XE3-59S)
5194	1	Reverse Gear Housing
19153	1	Thrust Washer (3XE-235A)

* Note: When ordering shaft half couplings, the following "Key Letters" should be used in conjunction with the basic shaft half coupling number:

A 3/4"	E 1-1/4"	I 1-3/4"
B 7/8"	F 1-3/8"	J 1-7/8"
C 1"	G 1-1/2"	K 2"
D 1-1/8"	H 1-5/8"	

Be Sure To Give Engine Number When Ordering Parts

Part No.	No. Reqd.	Name
----------	-----------	------

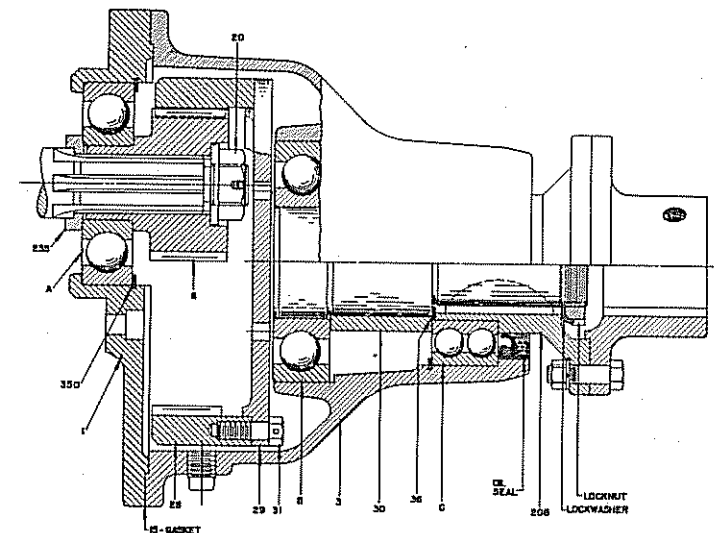

REDUCTION GEAR

REDUCTION GEAR ASSEMBLY RC-25

19423	1	WBR Red. Gear Assy. - Std. Rot. 2-1/2:1 (RC-25 Spec. Z6182)
19424	1	WBRO Red. Gear Assy. - Opp. Rot. 2-1/2:1 (RC-25-0) Spec. Z6182-0)
19414	1	Red. Gear Housing (RC20-3H)
19415	1	Pinion Gear Std. Rot. (RC25-6B)
19416	1	Pinion Gear Opp. Rot. (RC25-0-6B)
19359	1	Pinion Gear Nut (RDB-20)
19299	1	Coupling Nut (RC-N10)
19300	1	Coupling Lockwasher (RC-W10)
19306	1	Housing Gasket (RC20-15)
19308	1	Ring Gear - Std. Rot. (RC20-28)
19311	1	Ring Gear - Opp. Rot. (RC20-0-28)
19312	1	Ring Gear Flange & Shaft (RC20-29)
19313	1	Ball Bearing Spacer (RC20-30)
19417	8	Ring Gear Screws (RC20-31)
19314	1	Shaft Coupling-Gear Half (RC20-208)
	1	Coupling Key (Woodruff #31)

Be Sure To Give Engine Number When Ordering Parts

Part No.	No. Reqd.	Name
----------	-----------	------

REDUCTION GEAR ASSEMBLY RC-25 (Cont'd)

*2319	1	Shaft Coupling-Shaft Half (Give Shaft Size)
19218	1	Bearing Retaining Ring (7X-350)
19393	1	Bearing Retaining Ring (RDD-350C)
4392	1	Front Ball Bearing (5311-W)
3146	1	Center Ball Bearing (218-W)
3148	1	Rear Ball Bearing (5215-W)
19309	1	Cork Gasket (RC20-36)
3150	1	Rear Oil Seal (RC-446)

REDUCTION GEAR ASSEMBLY RC-20

19425	1	WBR2 Red. Gear Assy. - Std. Rot. - 2:1 (RC-20 Spec. Z-6181)
19426	1	WBR02 Red. Gear Assy. - Opp. Rot.- 2:1 (RC-20-0 Spec. Z-6181-0)
19414	1	Red. Gear Housing (RC20-3H)
19304	1	Pinion Gear-Std. Rot. (RC20-6)
19310	1	Pinion Gear-Opp. Rot. (RC20-0-6)
19359	1	Pinion Gear Nut (RDB-20)
19299	1	Coupling Nut (RC-N10)
19300	1	Coupling Lockwasher (RC-W10)
19306	1	Housing Gasket (RC20-15)
19308	1	Ring Gear-Std. Rot. (RC20-28)
19311	1	Ring Gear-Opp. Rot. (RC20-0-28)
19312	1	Ring Gear Flange & Shaft (RC20-29)
19313	1	Ball Bearing Spacer (RC20-30)
19417	8	Ring Gear Screws (RC20-31)
19314	1	Shaft Coupling-Gear Half (RC20-208)
	1	Coupling Key (Woodruff #31)
*2319	1	Shaft Coupling-Shaft Half (Give Shaft Size)
19393	2	Bearing Retaining Ring (RDD-350C)
3144	1	Front Ball Bearing (410-H)
3146	1	Center Ball Bearing (218-W)
3148	1	Rear Ball Bearing (5215-W)
19309	1	Cork Gasket (RC20-36)
3150	1	Rear Oil Seal (RC-446)

Be Sure To Give Engine Number When Ordering Parts

Part No.	No. Reqd.	Name
----------	-----------	------

REDUCTION GEAR ASSEMBLY RB-15

19271	1	WBS Red. Gear Assy. - Std. Rot. 1-1/2:1 (RB-15 Spec. Z-6056)
19427	1	WBSO Red. Gear Assy. - Opp. Rot. 1-1/2:1 (RB-15-0 Spec. Z-6056-0)
19284	1	Red. Gear Housing (RB20-3J)
19273	1	Pinion Gear-Std. Rot. (RB15-6)
19279	1	Pinion Gear-Opp. Rot. (RB15-0-6)
19395	1	Pinion Gear Washer (RDD-366)
19394	1	Pinion Gear Nut (RDD-363)
19269	1	Coupling Nut (RB-N09)
19270	1	Coupling Lockwasher (RB-W09)
19290	1	Housing Gasket (RB20-15)
19291	1	Ring Gear-Std. Rot. (RB20-28)
19292	1	Ring Gear-Opp. Rot. (RB20-0-28)
19293	1	Ring Gear Flange & Shaft (RB20-29)
19294	1	Ball Bearing Spacer (RB20-30)
19295	8	Ring Gear Screws (RB20-31)
19297	1	Shaft Coupling-Gear Half (RB20-208)
	1	Coupling Key (Woodruff #T)
*2313	1	Shaft Coupling-Shaft Half (Give Shaft Size)
19218	1	Bearing Retaining Ring (7X-350)
19391	1	Bearing Retaining Ring (RDD-350)
4390	1	Front Ball Bearing (311-W)
3158	1	Center Ball Bearing (312-W)
3160	1	Rear Ball Bearing (5212-W)
19296	1	Cork Gasket (RB20-36)
3162	1	Rear Oil Seal (RB-446)

Be Sure To Give Engine Number When Ordering Parts