

**INSTRUCTION BOOK**  
and  
**PARTS LIST**  
for  
**CHRIS-CRAFT MARINE ENGINES**

6 Cylinder 105 Horse Power Model KL Series  
6 Cylinder 131 Horse Power Model KBL



BOOK NO. ONE

**Chris-Craft Corporation**

Algonac, Michigan

U. S. A.

Cable Address: Chriscraft, Algonac

Printed in U. S. A.

## Chris-Craft Warranty

The Chris-craft boats, and/or Chris-Craft parts manufactured by Chris-Craft Corporation are warranted to be free from defects in material or workmanship under normal use and service; the Company's obligation under this warranty being limited to replacing or repairing any part or parts thereof, which shall disclose defects within SIX MONTHS after date of delivery of such boat or part to the original purchaser, and which examination by Company shall determine to be defective or not up to specifications; providing that Dealer shall make claim thereon and return said part or parts to Company, transportation prepaid, within 30 days after defect is discovered. This warranty being expressly in lieu of all other warranties expressed or implied, and of all other obligations or liabilities on the part of Company. The Company does not authorize Dealer, or other person to assume for Company any liability in connection with said warranty of Chris-Craft motor boats and/or parts.

This warranty shall not apply to any Chris-Craft boat and/or part manufactured by Chris-Craft Corporation, which shall have been altered or repaired outside of the factories of Chris-Craft Corporation or by use of parts not made or sold by the Company, in any way that, in the Company's judgment affects its stability or reliability, or which has been subject to misuse, neglect or accident.

This warranty will not apply to any engines, engine accessories, or trade accessories, not of our manufacture which we may use as these are generally warranted by their respective manufacturers.

This warranty does not cover race boats or racing engines, or boats and engines used for commercial purposes.

Catalogue speeds are attained over certified course at Algonac, Michigan, under favorable conditions and are not guaranteed.

CHRIS-CRAFT CORPORATION,  
Algonac, Michigan

## BREAKING IN A NEW ENGINE

The first few hours of operation have a great deal to do with the successful performance of an engine. Engines properly broken in will give much longer satisfactory service.

Before leaving the Chris-Craft factory, your engine has had several hours of "run-in" on the block test and is satisfactory for speeds up to 1500 R.P.M. It should be run for at least 5 hours at not over 1500 R.P.M. and then not over 2000 R.P.M. for the next 5 hours. The engine should not be run at maximum throttle for more than two or three minutes at a time until after the engine has had at least 20 hours.

A good way to tell how the break-in period is progressing, is to idle the engine at 1000 R.P.M., turn off the ignition and note how quickly the engine comes to a stop. You will note that the new engine will stop at once but as the break-in progresses, you will note that it does not stop with such a sudden jerk.

An abnormal rise in temperature on the temperature gauge will indicate that you are running a little too fast.

It is recommended that a pint of oil be added to each 5 gallons of gasoline for the first few hours of running. Be sure that it is mixed thoroughly in the tank.

During the entire life of the engine, always run the engine at medium speeds for a few minutes to allow the oil to warm up before running at sustained high speeds.

When coming to the dock, after a run, always allow the engine to run at moderate speed for at least 3 to 5 minutes before turning off the ignition. This can be done by slowing down several hundred yards before you get to the dock and coming in slow or letting the engine idle after you have come into the dock. This is to allow the valves to cool down while the water is still circulating in the engine. This will prevent warped valves.

## ENGINE LUBRICATION

The capacity of the engine lubricating system should be governed entirely by the marking on the oil level test rod.

Test rod No. 4184, regularly furnished, is used on the engines with "Running Angle" of 5° to 15° and is so indicated on tag attached to test rod. Boats with "Running Angle" of 16° to 24° should procure our No. 4186 oil level test rod.

Oil capacity will vary from 5-12 quarts depending on "Running Angle".

The oil should be changed after the first ten or fifteen hours running of the motor and then after every forty or fifty hours.

Commercial boats and others having unusual conditions due to engine placement or loads increasing their "Running Angle" beyond 24° or below 5° can only determine their high and low oil levels as follows:

1. The boat being "at rest", remove oil inspection plate and fill with oil until the highest point of the strainer (away from

2. Add (2) quarts more oil. Mark oil test rod (High)
3. Two quarts addition as noted above should be your normal high. At no time however should number 6 rod (above oil strainer) dip more than 1/2" in oil.

## To Change Oil

To drain the oil use the piece of copper tubing with fitting that will be found in the tool kit. Unscrew the oil pressure gauge line from the fitting where it goes into the engine on the side of the cylinder block behind the ignition coil. Put the end of this tube in a pail and idle the engine slowly which will pump all of the oil out of the crankcase. Do not speed up the engine and watch it closely and stop the engine as soon as the oil stops running out of the tube.

This is usually sufficient for a normal or average oil change. It does not take out sludge below the screen or remove the oil in the reduction or reverse gear. For a more complete oil change the oil may be pumped out of the crankcase by using a hand sump pump having a 1/4" x 18" copper tube fitted to it. Then by removing inspection cover on top of the reverse gear housing, the oil may be pumped out of this unit also. On reduction gear models there will remain from 1 to 1 1/2 quarts in that unit that cannot be removed.

## Recommended Lubricant

We are, of course, primarily interested in seeing that every Chris-Craft is serviced with good oil of character and quality, because the use of such an oil means not only dollars in the owner's pocket, but smooth engine operation, freedom from trouble, and maximum engine performance. A marine engine works at maximum capacity virtually 90 per cent of its lifetime, whereas in an automobile, the engine rarely, if ever, works at the maximum more than 10 per cent or 15 per cent of its life time. Hence the demands on the oil are far greater in a marine engine.

For the engine in all Chris-Craft boats we recommend a high quality marine engine oil, the proper grade of which will be found stamped on the number plate attached to the manifold.

## AUTO-LITE ELECTRICAL INSTRUCTIONS

Auto-Lite equipment is guaranteed and serviced by the Electric Auto-Lite Company of Toledo, Ohio. This service is handled through their many Official Service Stations located in all of the more important cities throughout the world. A directory of these Official Service Stations will be furnished any Auto-Lite user by request addressed to the Part and Service Division, the Electric Auto-Lite Company, Toledo, Ohio.

## General Care of the Electrical Equipment

Most important in the care of the electrical equipment is the keeping of all connections not only clean and tight mechanically, but free from all corrosion. Brass or copper connections in a boat operated around salt water are especially subject to corrosion and they should

be taken apart two or three times a year, cleaned with fine sandpaper, given a light coating of vaseline and reconnected, being sure they are tight.

Battery terminals should be given special attention and much trouble and annoyance can be avoided if they are periodically taken apart and washed in a strong ammonia or soda solution, given a light coating of vaseline and reassembled, being sure they are tight.

When replacing worn parts only genuine Auto-Lite service parts should be used. While the market affords numerous imitation parts there is no assurance that these are built of the same carefully selected material or are subject to the same exacting inspection as the genuine parts. Therefore, in order to insure yourself the longest possible life to the electrical equipment only genuine Auto-Lite parts should be used.

#### Generator

The generator output should never be set above the maximum output as noted on the nameplate. All wiring and connections should be tight and the proper size as high resistance in the charging circuit will cause an over voltage that materially shortens the life of lamps or other electrical equipment. The owner should not attempt to repair or adjust the circuit breaker or regulator as these operations should only be handled by an Official Service Station which is equipped with the proper tools and information to correctly repair these units.

#### Starting Motor

The starting motor requires no special attention except to see that it is mounted securely and that the Bendix is free from dirt. There should be no voltage loss in the starting circuit and switch as a reduced voltage reduces the cranking power of the motor.

#### Lubrication

Every 40 hours of engine use the following points should be lubricated with a medium engine oil:

1. The oilers in each end of the generator should be given 3 to 5 drops.
2. The intermediate oiler, if provided, and the commutator oiler, in the starting motor should be given 3 drops.
3. The oiler on the outside of the distributor housing should be given 3 to 5 drops.

Every season the distributor cap and rotor should be removed and one drop of light oil put on the breaker arm hinge pin, a light wipe of grease on the cam and a few drops of light oil added to the hole in the top of the distributor drive shaft.

#### CARBURETOR

The carburetor is guaranteed and serviced by the Zenith-Detroit Corporation, Foot of Hart Avenue, Detroit, Michigan.

Any service problems may be taken up with them or with the Chris-Craft Service Department.

#### FUEL PUMP

Service on the A C Fuel Pump is available through United Motors Service Branches and authorized A C Service Stations who are prepared with parts and fixtures for repairing all types of pumps.

Any service problems may be taken up with them or with the Chris-Craft Service Department.

#### REVERSE GEAR

##### Important Recommendation

It is not recommended that the boat be run at the dock with the reverse gear in the neutral position. Space here will not permit a detailed diagram on the construction and operation of a reverse gear but let it suffice to say that when the reverse gear is in the neutral position it compares to an automobile when the clutch pedal is pushed to the floor.

If you wish to warm up the engine at the dock put the nose of the boat against the dock and put the lever in the go-ahead position and run the engine slowly.

If you are familiar with the operation of the reverse operation of the gear you will know that in reversing, the reverse band is clamped firmly to the clutch drum. Therefore, it is important that the reverse lever be pulled back firmly so that the band will not slip on the drum. Pull the lever back and hold it there as long as you want to reverse and control the speed by the throttle and not by allowing the band to slip. It is not intended that the reverse gear be used as a brake.

##### Adjustments

It is necessary that your reverse gear be properly adjusted before you operate it. The forward drive is obtained by means of a multiple disc clutch. The locking or clamping of these discs is brought about by the pressure produced by the outward movement of the fingers when the operating lever is thrown into the forward position. On the forward drive the whole reverse gear is locked together as a solid coupling. Unless the pressure on these discs is great enough to lock the whole gear together under full load, the clutch will slip and heat.

The reverse drive is obtained by clamping the brake band around the outside drum or case which carries the pinion gears. The reverse motion is obtained by driving through the gears. Unless the band is clamped tight enough to keep this gear cage from revolving, it will slip in the reverse position.

In neutral position, both discs and the brake band are free and the gears run idle.

##### Adjustment for the Forward Drive—(See Page 17)

If the gear slips in the forward drive, back out the lock screw No. 76 until the end of it is clear of the hole in the pressure disc No. 11. Then turn the adjusting finger collar No. 28 to the right until the lock screw No. 76 is opposite one of the holes in the pressure disc

Then tighten up the lock screw No. 76 and be sure that the end of screw enters the hole in the pressure disc No. 11. Repeat this procedure until the reverse gear holds on the forward drive. An adjustment of one or two holes is usually sufficient.

#### Adjustment for the Reverse Drive—with Cam Clamping Mechanism

Throw the lever into the reverse position with the engine turning over slowly. Then tighten up the adjusting bolt No. 330 until the brake band clamps or grips the case or gear Cage No. 1 and holds it from revolving. It is well to screw up this adjusting bolt No. 330 a little tighter than is necessary. This will compensate for any wear on the brake band. The lock wire holds the adjusting bolt and keep it from loosening.

#### Adjustment for the Reverse Drive—with Toggle Clamping Mechanism

In the reverse position the brake band is supposed to grip and hold the gear cage or drum from turning. If this drum slips, it is necessary to tighten the adjustment of the brake band, which adjustment is made as follows:

Loosen the locknut No. 429 on the inside of the upright lug at the top of the brakeband to the amount you think the brake band needs adjusting. Then tighten the adjusting nut No. 431 on the outside of this lug until it is again tight against this lug. Repeat until the brake band grips the gear cage and keeps it from revolving.

The adjustment should be tight enough so that a decided snap is felt when the lever is thrown into the reverse position.

### ADJUSTMENT OF VALVES

It is not possible to put a final adjustment on the valves at the factory that will last for the entire season. After a few hours running the boat should be taken back to the dealer and the valves readjusted. Loss of engine speed and increase in gasoline consumption is the first indication of the need for grinding valves. An engine that is driven at sustained high speeds will need valve grinding much oftener than one used at normal speeds.

### CARE OF WATER PUMP

The water pump on current model engines are equipped with a water seal that will require no adjustment. When leaks occur this seal may be replaced.

### ADJUSTMENT OF SPARK

The surfaces of the contact points should be cleaned, free from rough pittings and grease. After 500 hours running of the boat it may be necessary to reface these contacts, or to install a new set. The same applies to spark plugs, and when the points become worn and corroded new plugs should be installed. It is important that only the correct type of plug be used in this motor. See page 8.

To adjust the spark—Run the boat with the engine at about 2500 R.P.M. (2000 on Cruisers) and advance the spark until it starts to rattle. At this point speed will drop off, indicating detonation. Then retard it just enough to make the engine run smoothly without any rattle or spark knock. Make this adjustment with the gear in forward position. Do not attempt it with the gear in neutral.

### ADJUSTMENT OF CARBURETOR

To adjust the carburetor for high speed—Screw the needle valve on the carburetor all the way in; then back it out about one and three-quarter turns. This should make it just a trifle too rich. Run the boat at full throttle and screw the needle valve in until the speed starts to drop off. (Watch the tachometer closely.) Then unscrew it until the engine runs at highest speed. The approximate setting is about one and one half turns open. A too lean mixture will cause pre-ignition and burned valves. It is better to run a little on the rich side.

### ENGINE ALIGNMENT

Many cases of excessive vibration, reverse or reduction gear noise, and loss of revolutions, are caused by engine misalignment. This alignment is checked by disconnecting the two halves of the shaft coupling just aft of the reverse or reduction gear. The faces of these flanges must be within .003 parallel in all directions. The engine is mounted on taper shims to facilitate this adjustment. For further information refer to the paragraph on this subject in the Boat Owners' Manual.

### ENGINE KNOCKS AND LOSS OF REVOLUTIONS

A sudden and otherwise inexplicable drop in revolutions, a new and disturbing period of vibration, and a sudden loss of speed without other apparent cause, are usually definite symptoms of propeller wheel disorders even though the propeller wheel itself looks to be undamaged.

Never attempt to judge the condition of a propeller from its appearance. Though undamaged to the naked eye it may show startling pitch discrepancies when subject to careful measurements with proper instruments. It is not necessary to run aground or to become entangled with drift in order to throw a propeller out of pitch. Especially in the case of high-speed, high-power run-abouts, loss of pitch will occur in the course of normal operation. A sudden turn at high speed, or bucking a heavy sea is often sufficient to submit one or more of the blades to a sudden shock or load beyond their normal ability to withstand, resulting in a propeller which, though not perceptibly damaged, is sufficiently "out of pitch" to account for several hundred lost R.P.M. on the tachometer or set up a serious vibration period.

Engine knocks are usually caused by faulty lubrication, and if you take proper care of the oiling of your motor you will probably never hear a knock.

Knocks which start suddenly and rapidly get louder are dangerous. Stop motor and investigate oil supply and water circulation, including water intake. Do not run a motor with a loose bearing.

Knocks which begin faintly and increase slowly if at all are not immediately dangerous, but should be investigated by a mechanic or your Chris-Craft dealer as soon as possible.

If you are caught offshore with a burned out rod bearing due to lack of oil in the crankcase and must run the motor in order to get to land, removing the spark plug in the bad cylinder is your best chance. Run slowly.

#### EXTRA GALLON OF OIL

An extra gallon of oil of the proper grade and quality is usually included in the equipment. It is recommended that it be left in the boat to be used in an emergency. In case of an accident it may save you a costly repair bill.

#### MISFIRING

The most frequent causes of misfiring are as follows: (It is entirely unlikely that you will be troubled with any of these things, but it is well to know what to do in case of emergency): 1—Dirty or cracked plugs; remedy—install new ones or clean them. 2—Intermittent electric leak somewhere in the wiring; remedy—trace and insulate. 3—Stuck valve, or broken valve spring. Remove valve cover plate and inspect valve mechanism; remedy—new springs or grinding valves, or both. 4—Valve tappets too close. At high speed close-set tappets will ride the cams, prevent the valves from closing, and thus cause misfiring; remedy—adjust tappets. 5—Breaker points out of adjustment; when a motor misses at low speeds only, inspect breaker points first. 6—Water in one or more cylinders due to blown gaskets or crack in water jacket. 7—Blown or leaky gaskets, either in manifold or cylinder head. 8—Loose spark plugs. 9—Too high oil level, causing sooty plugs.

#### IMPORTANT NOTICE

Form the habit of watching the oil pressure gauge. This gauge is sometimes called the "watch dog" of the engine. Advance notice of serious trouble is nearly always given by the oil gauge. If the pressure suddenly drops off, stop the engine immediately and do not run it until the trouble is located and remedied. See if there is plenty of oil in the crankcase. An oil line may be broken or the gauge broken—Try a new gauge first. If the oil pressure suddenly goes too high look for a plugged oil line or the relief valve may be stuck. If the oil pressure falls off gradually, the oil may be worn out or diluted with gasoline. Do not change the oil pressure regulating valve to compensate for sudden changes in oil pressure or to compensate

#### USEFUL INFORMATION

##### Engine

Type—L-Head, vertical

Cylinders—6

Bore—3-7/16"

Stroke—4 1/4"

Brake Horsepower— Model KL—105

Model KBL—131

Piston Displacement—Model KL and KBL—236.6 cu. in.

Compression Ratio— Model KL and KBL—7.52

Weight— KL—626 lbs.

KLS—676 lbs.

KLR—710 lbs.

KBL—626 lbs.

##### Electrical System—6 volt

Battery—6 volt

Generator charging rate—18 to 20 amperes max.

Generator cuts in at—800 R.P.M.

##### Oiling System

5 pounds (minimum)—idling speed

20 to 30 pounds—maximum speed, hot

#### SPECIFICATIONS AND ADJUSTMENTS

Valve Clearance—Engine cold

Exhaust Valve—.014

Intake Valve—.010

Valve Seat—Exhaust 1 1/4"—Face of seat 1/16" wide

Intake 1 3/8"—Face of seat 3/32" wide

Valve Guide Clearance—

Exhaust—.0025 to .003

Intake—.001 to .0015

Push Rod—.00075 to .001

Idler Gear Clearance—.0005 to .0015 backlash

Camshaft bearing clearance—.001 to .002

Crankshaft main bearing clearance—.0015 to .003

Crankshaft thrust clearance—.004 to .008

Crank pin bearing clearance, end—.005 to .010

Rod to Shaft—.001 to .003

Piston Clearance, at skirt—.0035 to .004

Piston pin clearance—Hand push fit

Piston Ring Gap—.015 to .020

Piston Ring Side Clearance in Grooves—

Top Groove—.0035 to .005

2nd Groove—.0015 to .003

3rd Groove—.0015 to .003

Distributor Point Gap—.022

Spark Plug—J-8—J-F

Spark Plug Gap—.028

#### TO DRAIN THE WATER SYSTEM

Open drain cock on side of cylinder block behind the water pump. Remove plug at bottom of water pump and plug in water line tee in

# PARTS LIST

## CHRIS-CRAFT MARINE MOTOR

MODEL KBL - KL - KLO

See Your Chris-Craft Dealer or write direct to Factory for Prices

Part No.	No. Reqd.	Name
<b>STRIPPED ENGINE ASSEMBLIES AND CYLINDER AND CRANKCASE</b>		
3592	1	KBL—Stripped Engine Assembly with Valves, Pistons Crankshaft, Camshaft and Connecting Rods 3 7/16" Bore
3596	1	KL—Stripped Engine Assembly—Standard Rotation— with Valves, Pistons, Crankshaft, Camshaft and Connecting Rods—3 7/16" Bore
3598	1	KLO—Stripped Engine Assembly—Opposite Rotation— with Valves, Pistons, Crankshaft, Camshaft and Connecting Rods—3 7/16" Bore
49687AS	1	Cylinder and Crankcase Only—with Valve Guides, Camshaft Bushings and Idler Gear Bushings
3590	1	Set Main Bearings, consisting of: 2—43598B Front Bearings—Upper & Lower 2—43601B Center Bearings—Upper & Lower 2—47093B Rear Bearings—Upper & Lower 8—43600B Inter-Bearings—Upper & Lower
40070A	10	Main Bearing Cap Screw—Front and Intermediate—1/2" x 2"
40071A	8	Main Bearing Cap Screw—Center and Rear—7/16" x 2"
4731A	10	Main Bearing Cap Screw Lockwasher—1/2"
4732A	8	Main Bearing Cap Screw Lockwasher—7/16"
14398A	1	Cylinder Drain Cock
7239A	8	Expansion Plug—1 1/2"—Brass
60A	1	Oil Passage Pipe Plug—1/4"—Slotted
59A	8	Oil Passage Pipe Plug—1/4"—Slotted
3201A	1	Oil Passage Pipe Plug—1/4"—Special Slotted
1702	1	Cylinder Block Water Jacket Plate—Large
1713	1	Cylinder Block Water Jacket Plate Gasket—Large
1687	1	Cylinder Block Water Jacket Plate—Small
1688	1	Cylinder Block Water Jacket Plate Gasket—Small
46028A	4	Cylinder Block Valve Compartment Plug
40555B	4	Front Main Bearing Thrust Washer—Bronze
40554A	4	Front Main Bearing Thrust Washer Pin
<b>GASKET SET</b>		
3258	1	Set of Gaskets—Complete—KBL—KL—KLO
<b>CONNECTING ROD</b>		
47091AS	6	Connecting Rod—with Bearing and Bolts
46156A	12	Connecting Rod Bolt
46157A	12	Connecting Rod Bolt Nut
301A	12	Connecting Rod Bolt Nut Cotter Pin (3/32" x 3/4")
46111A	6	Connecting Rod Clamp Screw (Holds Pin)
14842A	6	Connecting Rod Clamp Screw Lockwasher
46154A	36	Connecting Rod Shim .003
46167A	As Req.	Connecting Rod Shim .002
47092B	12	Connecting Rod Bearing—Upper and Lower

Part No.

No. Reqd.

Name

### PISTONS

49232C	6	Pistons KL and KBL—3 7/16" Dia.—Standard Rotation
47121C	6	Pistons KLO—3 7/16 Dia.—Opposite Rotation
46022B	6	Piston Pins
3584	1	Set Piston Rings, Order by Set

Note: Pistons and rings are supplied in the following oversize—.020. Piston pin supplied in .003 and .005 oversizes. On orders for sizes other than specified above an additional 25 pct. will be added.

### CRANKSHAFT

49525	1	Crankshaft—KBL-KL-KLO
46039A	1	Crankshaft Gear—Standard
46040B	1	Crankshaft Gear—Opp. Rotation
4413A	1	Crankshaft Gear Key
1707A	2	Crankshaft Dowel

### VALVES

47017B	6	Intake Valve
47016B	6	Exhaust Valve
46043A	12	Valve Spring
46017A	12	Valve Guide
46013A	12	Valve Spring Seat
46011A	24	Valve Spring Seat Lock
46007B	1	Valve Cover—Aft
3710	1	Valve Cover and Fume Tube Ass'y.—KBL
4118	1	Valve Cover and Fume Tube Ass'y.—KL
3402	4	Valve Cover Screw Gasket
4337A	4	Valve Cover Screw—3/8-16 x 2
46008B	2	Valve Cover Gasket
46028A	4	Valve Compartment Plug

### ALL ENGINE NUMBERS

46043A	12	Valve Spring
46013A	12	Valve Spring Seat
46011A	24	Valve Spring Seat Lock
46007B	1	Valve Cover—Aft
3710	1	Valve Cover and Fume Tube Ass'y.—KBL
4118	1	Valve Cover and Fume Tube Ass'y.—KL
3402	4	Valve Cover Screw Gasket
4337A	4	Valve Cover Screw—3/8-16 x 2
46008B	2	Valve Cover Gasket
46028A	4	Valve Compartment Plug

### VALVE TAPPET

38010AS	12	Valve Tappet Assembly
46019A	12	Valve Tappet Adjusting Screw
14974A	12	Valve Tappet Screw Nut—Hardened
46089A	12	Valve Tappet Guide

Part No.	No. Reqd.	Name
<b>CYLINDER HEAD</b>		
3656	1	Cylinder Head—Cast Iron
46372C	1	Cylinder Head Gasket
3668	20	Cylinder Head Studs—Short
3664	2	Cylinder Head Studs—Long
3574	2	Capscrews, Hex Head— $\frac{1}{2}$ "—13 x 3"
3374	24	Cylinder Head Stud Plain Washer (Hardened)*
3286	22	Cylinder Head Stud Nut— $\frac{1}{2}$ "—No. 20
3688	3	Cylinder Head Expansion Plugs— $1\frac{1}{8}$ "
4312A	1	Cylinder Head Temperature Gauge Plug— $\frac{1}{2}$ "
1826	1	Cylinder Head Water Outlet Fitting
1827	1	Cylinder Head Water Outlet Fitting Gasket

**SUPPORT BRACKETS**

1613	1	Engine Front Support Bracket (Does not include rubber mounting)
1685	1	Engine Front Support Bracket to Cylinder Gasket
1624	1	Engine Rear Support Bracket
1627	1	Engine Rear Support Bracket Gasket
1777	2	Engine Rear Support Bracket Dowel Bushing
1674	4	Engine Support Bracket (On Keelson)
1430	4	Engine Rubber Mounting
1634	2	Reverse Housing to Cylinder Block Stud

**CAMSHAFT**

46814D	1	Camshaft—With Plunger—Standard—KL
46816D	1	Camshaft—With Plunger—Opp. Rotation—KLO
46041A	2	Camshaft Bearing—Front and Rear
46044A	2	Camshaft Bearing—Center
46049B	1	Camshaft Gear—Standard
46050B	1	Camshaft Gear—Opp. Rotation
4265A	1	Camshaft Gear Key
46045A	1	Camshaft Thrust Washer
40068A	1	Camshaft Thrust Plunger
14956AS	1	Camshaft Thrust Adj. Screw Assembly
1823	1	Camshaft with Plunger—Standard—KBL
1933	1	Camshaft with Plunger—Opp. Rotation—KBLO

**IDLER GEAR**

46138B	1	Idler Gear—Standard Rotation
46141B	1	Idler Gear—Opp. Rotation
46139A	1	Idler Gear Shaft—With Plunger
22107A	1	Idler Gear Thrust Washer
46140A	1	Idler Gear Shaft Bearing
40068A	1	Idler Gear Shaft Plunger
14956AS	1	Idler Gear Thrust Adj. Screw Assembly

**ACCESSORY DRIVE**

47072BS	1	Accessory Drive Assembly—Standard Rotation
47074BS	1	Accessory Drive Assembly—Opp. Rotation
46195B	1	Accessory Drive Gear—Standard
46077B	1	Accessory Drive Gear—Opp. Rotation
4413	1	Accessory Drive Gear Key
27072A	1	Accessory Drive Shaft

Part No.	No. Reqd.	Name
<b>ACCESSORY DRIVE—(Continued)</b>		
27257A	1	Accessory Drive Bushing
46170A	1	Accessory Drive Attaching Gasket
1864	1	Accessory Drive Attaching Screw— $\frac{3}{8}$ " x 1"
682A	2	Accessory Drive Attaching Screw— $\frac{3}{8}$ " x $2\frac{3}{4}$ "
342A	3	Accessory Drive Attaching Screw Lockwasher— $\frac{3}{8}$ "
40068A	1	Accessory Drive Thrust Plunger
4024A	1	Accessory Drive Thrust Washer
47073C	1	Accessory Drive Housing
22336A	1	Accessory Drive Distributor Driving Gear—Standard
27073A	1	Accessory Drive Distributor Driving Gear—Opp. Rotation
1179A	1	Accessory Drive Distributor Driving Gear Key
300A	1	Accessory Drive Distributor Clamp Nut
8051A	1	Accessory Drive Distributor Clamp Screw
14956AS	1	Accessory Drive Thrust Adj. Screw Assembly

**FLYWHEEL**

1902	1	Flywheel—With Ring Gear—KBL
1900	1	Flywheel—With Ring Gear—Standard Rotation—KL
1901	1	Flywheel—With Ring Gear—Opp. Rotation—KLO
22104A	4	Flywheel Bolt
1609	4	Flywheel Bolt Nut
1562	1	Flywheel Ring Gear—Standard Rotation
1563	1	Flywheel Ring Gear—Opp. Rotation
1434	1	Starting Crank—Cruiser (Long)
1488	1	Starting Crank—Runabout (Short)

**OIL PAN**

1612	1	Oil Pan
1626	2	Oil Pan Gaskets
2011	1	Oil Strainer Body and Screen
1639	1	Oil Strainer to Pump Flexible Tube Assembly
3570	1	Tube Elbow Fitting— $\frac{3}{4}$ "-16"; $\frac{3}{8}$ " Female Pipe Thread
4312A	1	Oil Drain Plug— $\frac{1}{2}$ " Square Head
3578	1	Oil Drain Tube Assembly

**OIL FILLER**

1611	1	Oil Filler and Inspection Plate
1610	1	Oil Filler and Inspection Plate Gasket
4184	1	Oil Level and Test Rod—5° to 15° Running Angle
4186	1	Oil Level Cap and Test Rod—16° to 24° Running Angle

**OIL PUMP**

43366CS	1	Oil Pump Assembly—Standard Rotation
43367CS	1	Oil Pump Assembly—Opposite Rotation
22119A	1	Oil Pump Attaching Gasket
45266A	1	Oil Pump Drive Gear—Standard Rotation
45275A	1	Oil Pump Drive Gear—Opposite Rotation
2047A	1	Oil Pump Drive Gear Washer
4809A	1	Oil Pump Drive Gear Pin

(Additional detail parts can be furnished on request, but we recommend the pump be returned to the factory when in need of repairs.)

Part No.	No. Reqd.	Name
<b>OIL PRESSURE REGULATING PARTS</b>		
22129A	1	Oil Pressure Regulating Piston
1347A	1	Oil Pressure Regulating Spring
1385A	1	Oil Pressure Regulating Spring Cap
2058A	1	Oil Pressure Regulating Adj. Screw
1660A	1	Oil Pressure Regulating Adj. Screw Nut
28A	1	Oil Pressure Regulating Adj. Screw Lock Nut
<b>MANIFOLDS</b>		
4122	1	KL and KBL Exhaust Manifold
4102	1	Gasket—Exhaust Manifold to Block
3628	4	½" Aluminum Expansion Plug
1829	6	Stud—Exhaust Manifold—Short
1830	2	Stud—Exhaust Manifold—Long
4058	1	Exhaust Manifold End Cover
1741	1	Exhaust Manifold End Cover Gasket
1824	1	KBL Carburetor to Manifold Inlet Elbow—Front
3696	1	KBL Carburetor to Manifold Inlet Elbow—Rear
3698	1	KBL Carburetor to Manifold Inlet Elbow—Inter.
4158	2	KBL Carburetor Balancing Tube
1789	3	KBL Carburetor to Manifold Inlet Elbow—Gasket
1867	1	KL Intake Manifold
2423	3	KL Intake Manifold—Gasket
3362	1	KL Intake Manifold Water Jacket Drain Plug
3616	7	Connector ½" Tube x ¾" Male Pipe
4100	1	KL Water Line—End Cover to Intake Manifold
3196	1	KBL Manifold End Cover Plug ¾" Hex. Brass
4643A	1	KL Intake Manifold Expansion Plug ¾" Brass
3198	1	Exhaust Manifold Drain Plug ½" Hex. Brass
<b>KL EXHAUST ELBOW ASSEMBLIES</b>		
4112	1	KL—Vertical—Down
4114	1	KL—Turns Horizontal to Port
4116	1	KL—Turns Horizontal to Starboard
4130	1	KL—Twists 45° Down to Port
1745	1	KL—Exhaust Pipe Flange for 2½" Iron Pipe Thread
<b>KL INTAKE MANIFOLD TO EXHAUST ELBOW—WATER LINES</b>		
4104	1	Water Tube for 4112 Elbow Assembly
4108	1	Water Tube for 4116 Elbow Assembly
4106	1	Water Tube for 4114 Elbow Assembly
3618	1	Brass Elbow ½" Tube x ¾" Male Pipe (One Per Elbow)—KL
3616	1	Brass Connection ½" Tube x ¾" Male Pipe (One in Each Side Intake Manifold)—KL
<b>KBL EXHAUST ELBOW ASSEMBLIES</b>		
1740	1	KBL—Turns Horizontal to Port
1774	1	KBL—Vertical—Down
1775	1	KBL—Twists 45° Down to Port
1745	1	KBL—Exhaust Pipe Flange for 2½" Iron Pipe Thread

Note: All KL and KBL Exhaust Elbows as used in Chris-Craft Boats are designed for 2¾" O. D. Copper Exhaust Tube.

Part No.	No. Reqd.	Name
<b>LIFTING EYE</b>		
1662	1	Engine Lifting Eye
3296	1	Engine Lifting Eye Lockwasher—9/16"
<b>KL CARBURETOR</b>		
(Order Detail Parts Direct from Manufacturer)		
3614	1	KL Carburetor Ass'y. (Zenith 263M2E—12—No. 0—10762)
1789	1	KL Carburetor Gasket
4110	2	KL Carburetor Stud
539	1	KL Carburetor Flame Arrestor—(Zenith—B—1807)
2932	1	KL Carburetor Repair Kit—(Zenith—K—10762)
<b>KBL CARBURETORS</b>		
(Order Detail Parts Direct from Manufacturer)		
1571	3	KBL Carburetor Ass'y. (Zenith 28-B—12—No. S—1484)
1789	3	KBL Carburetor Gasket
1572	3	KBL Carburetor Flame Arrestor (Zenith B—1856)
1831	3	Throttle Control Bracket
4160	1	Throttle Control Shaft ¾" x 18" Brass Rod
0000	4	Throttle Control Shaft Lever Zenith D-2880
0000	4	Throttle Control Shaft Lever Screw Zenith D-603
4162	3	Throttle Control Link ¼" x 6½" Brass Rod—Threaded
7573	6	Throttle Rod Ball Joint
12927	1	KBL Carburetor Repair Kit (Zenith—K-S-1484)
<b>ELECTRICAL EQUIPMENT</b>		
1540	1	Generator—Auto-Lite—GEO-4807—Standard Rotation
1552	1	Generator—Auto-Lite—GEO-4809—Opposite Rotation
(Order Detail Parts Direct from Manufacturer)		
1711	1	Generator Retaining Screw
2003	1	Generator Pulley
1570	1	Generator Belt—2MO-37
4234	1	Starting Motor—Auto-Lite MCL-6004—Standard Rotation
4236	1	Starting Motor—Auto-Lite—MCL-6005—Opposite Rotation
(Order Detail Parts Direct from Manufacturer)		
3234	1	Distributor Ass'y.—Auto-Lite—IGW-4149-A—Standard Rotation
3236	1	Distributor Ass'y.—Auto-Lite—IGW-4149-A—Opposite Rotation
(Order Detail Parts Direct from Manufacturer)		
2335A	1	Distributor Driven Gear—Standard Rotation
27335A	1	Distributor Driven Gear—Opposite Rotation
1530	1	Tachometer Fitting
102871	1	Tachometer Fitting Set Screw—¼"—20 x ⅝" Cup Point
1410	1	Distributor Shaft Packing Gland
3474	As Req'd.	Distributor Shaft Packing Gland Washer
1469	1	Ignition Coil—Auto-Lite IG-6001
1861	1	Ignition Cable—Dist. to Coil—High Tension
1665	1	Ignition Cable—Dist. to Coil—Low Tension
1650	3	Ignition Cable—Dist. to Spark Plugs—Short
1651	3	Ignition Cable—Dist. to Spark Plugs—Long
1470	6	Spark Plugs—Champion—J-8—J-F
1833	1	Ignition Wire Conduit

Part No.	No. Reqd.	Name
<b>ELECTRICAL EQUIPMENT—(Continued)</b>		
3666	2	Ignition Wire Conduit Spacer
1869	14	Ignition Wire Conduit Grommet
4343A	1	Distributor Spark Control Arm Bracket
4266A	1	Distributor Spark Control Arm Bracket Screw 5/8"-16 x 1 1/4"
<b>WATER PUMP</b>		
4240	1	Water Pump Assy.—Standard or Opposite Rotation
3582	1	Water Seal
3466	1	Coupling and Pin Assembly
	1	Water Pump to Manifold Hose 3/4" x 16 1/2"
12551	2	Water Pump to Manifold Hose Clamp—3/4"
1671	2	Water Pump to Manifold Hose Nipple—1/2" x 2"
	1	Manifold Tee—1/2"
	1	Manifold Tee Nipple—1/2" x 2"
	3	Water Pump Inlet and Outlet Street Ell—1/2"
1671	1	Water Pump Inlet Hose Nipple—1/2" x 2"
4408	1	Water Pump Attaching Gasket
1698	1	Dual Water Pump—Standard Rotation Only
<b>KL AND KBL FUEL PUMP</b>		
(Order Detail Parts Direct from Manufacturer)		
1559	1	Fuel Pump Assembly Complete with Filter—AC-1537241
1462	1	Fuel Pump Gasket
12688	1	Fuel Pump Repair Kit—AC-1538625
<b>KL FUEL LINES AND FITTINGS</b>		
4120	1	KL Fuel Pump to Carburetor Fuel Line
3472	1	KL Straight Connector 5/16" tube x 1/8" Male Pipe
3412	1	KL Elbow 5/16" Tube x 1/8" Male Pipe
<b>KBL FUEL LINES AND FITTINGS</b>		
4164	1	KBL Fuel Line to Front Carburetor
4166	1	KBL Fuel Line to Center Carburetor
4168	1	KBL Fuel Line to Rear Carburetor
	1	1/8" Female Pipe Cross—Brass
	1	1/8" Brass Close Nipple
	5	Elbows—Brass—1/4" Tube x 1/8" Male Pipe
	1	Connector Brass 1/4" x 1/8" Male Pipe
<b>OIL COOLER</b>		
1548	1	Oil Cooler RV-20
1755	1	Oil Cooler Bracket
3402	1	Oil Cooler Stud Gasket (500E)
3254	2	Oil Cooler Cap Gasket
682A	2	Oil Cooler Bracket Capscrews 3/8"—16 x 2-3/4" S.A.E. Hex. Hd.
1770	1	Oil Cooler Stud
1551	1	Oil Pump Delivery Oil Line (7/16" O.D. x 9-5/8")
3602	1	Marine Elbow (7/16" Tube (1670 Spec. Nut.) x 1/4" Male I.P. Thread for connection at Oil Pump Cover
3566	4	Straight Marine Connectors (7/16" Tube) x 1/4" Male I.P. Thread—2 used at Oil Cooler—2 used at Block
1818	1	Oil Line—Cooler to Tee on Cylinder Block
1819	1	Oil Line—Cylinder Block to Oil Cooler
1664	1	Tee—Special (Oil Cooler to Cylinder Block Oil Line) (Used before Engine 50678)

Part No.	No. Reqd.	Name
<b>OIL COOLER—(Continued)</b>		
1772	1	Tee—Special (Oil Cooler to Cylinder Block Oil Line) (Used after Engine 50677)
1 Pc.		Hose (3/4" I.D.—3 Ply x 6 1/2" Water Hose) Pump to Cooler
1 Pc.		Hose (3/4" I.D.—3 Ply x 10" Water Hose) Cooler to Manifold
12551	4	Hose Clamps—3/4"
3362	1	Pipe Plug—1/8" Hex Head Brass I.P.T. (Oil Cooler Drain)
131643	1	Blind Nut—3/8"—24 Steel (For Oil Cooler Stud)
59A	1	Pipe Plug—1/8" Slotted (Used to plug Block Oil Line not used)
<b>REVERSE GEAR—DIRECT DRIVE (1XE-90) (Spec. Z-5354)</b>		
1XE-4Q	1	Engine Gear
1635	1	Engine Gear Retaining Screw
103323		1—1/2" Lockwasher
117983		1—No. 127 Woodruff Key
1XE-402	1	Pilot Roller Bearing
1XE-1A	1	Gear Cage or Drum
1XE-372	1	Gear Cage Front Bushing
OXX401	1	Gear Cage Rear Ball Bearing
1XE-8	4	Pinion Stud
1XE-5	2	Pinion Gear—Short—With Bushing
1XE-5A	2	Pinion Gear—Long—With Bushing
1XE-7A	6	Pinion Gear Bushing
1XE-3B	1	Propeller Gear
1XE-47B	1	Disc Driver

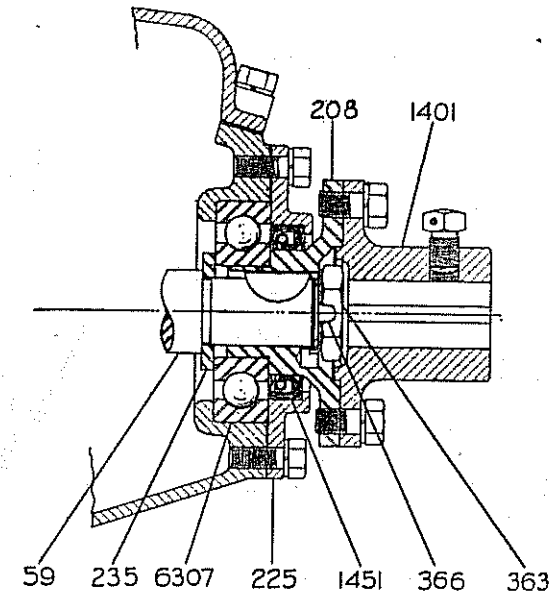

**REVERSE GEAR REAR END  
Direct Drive**

Numbers shown are key numbers only.  
Refer to parts list for complete part number.

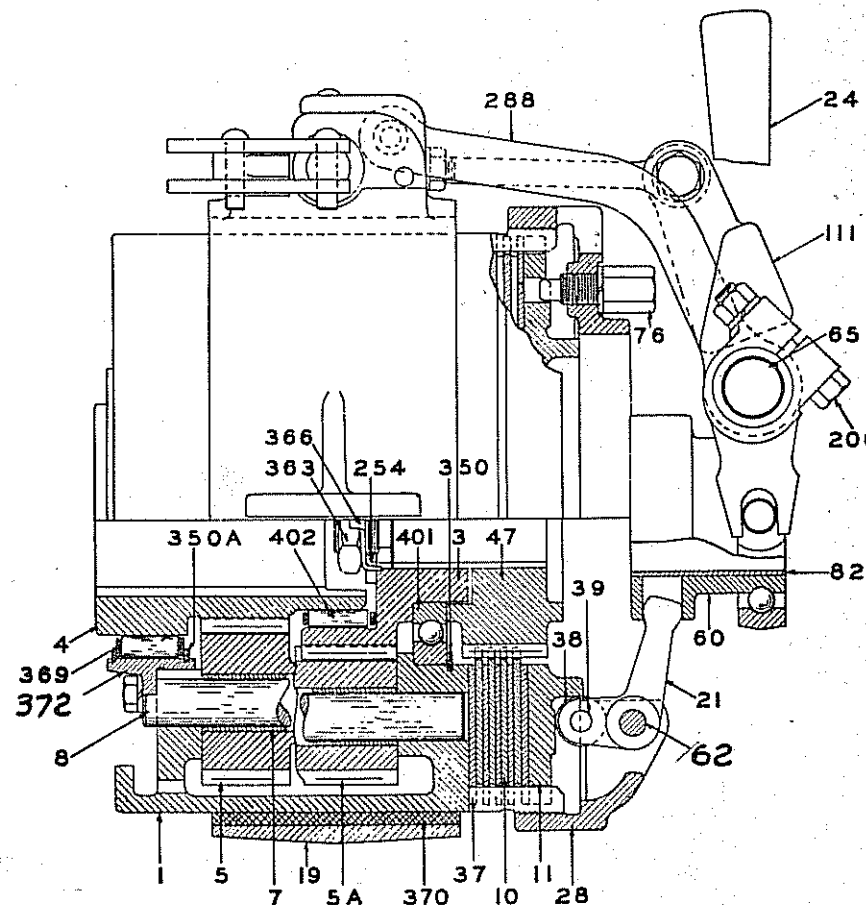
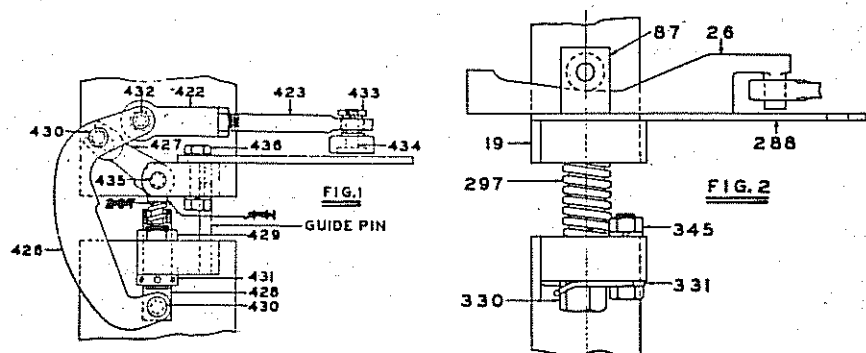

REVERSE GEAR

Numbers shown are key numbers only  
Refer to parts list for complete part number

Part No. No. Req'd. Name  
**REVERSE GEAR—DIRECT DRIVE—(1XE-90) (Spec. Z-5354)—(Continued)**

1XE-10A	3	Friction Disc—Inside—Bronze
1XE-37B	3	Friction Disc—Outside—Steel
1XE-11B	1	Finger Pressure Disc
1XE-28	1	Adjusting Finger Collar
2XE-76	1	Clutch Adjusting Lock Screw
1XE-21	3	Clutch Throwout Finger Assembly

**REVERSE GEAR REAR END**

1XE-60B	1	Operating Sleeve—With Ball Bearing Collar
111D	1	Clutch Throwout Yoke
1XE-65	2	Clutch Throwout Yoke Shaft
XS-24	1	Clutch Throwout Hand Lever
1XE-19C	1	Reverse Brake Band—Lined
1XE-370	1	Reverse Brake Band Lining
1XE-288	1	Reverse Brake Band Support
1XE-26A	1	Reverse Brake Band Locking Bar
X-330	1	Reverse Brake Band Adjusting Bolt—With Spring
1XE-59M	1	Reverse Gear Stub Shaft (For Shaft Flange)
1XE-235	1	Propeller Shaft Coupling Thrust Washer
1450	1	Thrust Bearing—S.K.F. No. 6307
1451	1	Housing Rear Oil Seal—Rawhide
RDA-225	1	Housing Rear Oil Seal Retainer
1416	1	Housing Rear Oil Seal Retainer Gasket
1452	2	Housing Operating Shaft Oil Seal—Rawhide
1615	1	Reverse Gear Housing
1621	1	Reverse Gear Housing Gasket
1386	1	Reverse Gear Housing Top Cover
1413	1	Reverse Gear Housing Top Cover Gasket
1XE-208	1	Propeller Shaft Flange—Engine Half
2XE-363	1	Propeller Gear Lock Nut
RDA-366	1	Propeller Shaft Nut Washer
1401	1	Propeller Shaft Flange—Shaft Half
1634	2	Reverse Gear Housing to Cylinder Block—Stud

**REVERSE GEAR—REDUCTION DRIVE (2XE-90) (Spec. Z-5477)**

2XE-4 L	1	Engine Gear
1636	1	Engine Gear Retaining Screw
	1	1/2" Lockwasher
	1	No. 127 Woodruff Key
2XE-402	1	Pilot Roller Bearing
2XE-1A	1	Gear Cage or Drum
2XE-372	1	Gear Cage Front Bushing
RDB-350A	2	Gear Cage Front Bearing Ring
1XE-401	1	Gear Cage Rear Ball Bearing
1XE-8B	4	Pinion Stud
2XE-5D	2	Pinion Gear—Short—With Bushing
2XE-5C	2	Pinion Gear—Long—With Bushing
2XE-7H	8	Pinion Gear Bushing
2XE-3B	1	Propeller Gear
2XE-47B	1	Disc Driver
2XE-10B	3	Friction Disc—Inside—Steel
2XE-37D	4	Friction Disc—Outside—Bronze
2XE-11B	1	Finger Pressure Disc
2XE-28	1	Adjusting Finger Collar
2XE-76	1	Clutch Adjusting Lock Screw
2XE-21	3	Clutch Throwout Finger Assembly
4X-62	3	Reverse Finger Hinge Pin
2XE-60B	1	Operating Sleeve—With Ball Bearing Throwout Collar

Part No.	No. Reqd.	Name
<b>REVERSE GEAR—REDUCTION DRIVE—(2xE-90) (Spec. Z-5477)—(Continued)</b>		
3XA-111	1	Clutch Throwout Yoke
3XA-65	2	Clutch Throwout Yoke Shaft
2XE-288A	1	Reverse Brake Band Support
2XE-59AB	1	Reverse Gear Stub Shaft (For Reduction Gear)
1452	2	Housing Operating Shaft Oil Seal—Rawhide
2449	1	Reverse Gear Housing—1½:1 Reduction Gear
2279	1	Reverse Gear Housing—2:1 Reduction Gear
1621	1	Reverse Gear Housing Gasket
1619	1	Reverse Gear Housing Top Cover
1620	1	Reverse Gear Housing Top Cover Gasket
2280	2	Reverse Gear Housing to Oil Pan—Stud
2XE-363	1	Propeller Gear Lock Nut
2XE-366A	1	Propeller Gear Lock Nut Washer
2XE-19D	1	Reverse Brake Band—Lined
2XE-370	1	Brake Band Lining
3XE-422	1	Brake Band Link End Yoke
3XE-423	1	Brake Band Link
3XE-426	1	Brake Toggle Lever—Long
3XE-427A	1	Brake Toggle Lever—Short
3XE-428A	1	Brake Adjusting Bolt
3XE-431	1	Brake Long Adjusting Bolt Adj. Nut
3XE-429	1	Brake Adjusting Bolt Lock Nut
3XE-430	2	Brake Toggle Lever Pins
3XE-432	1	Brake Toggle Lever Ball Joint

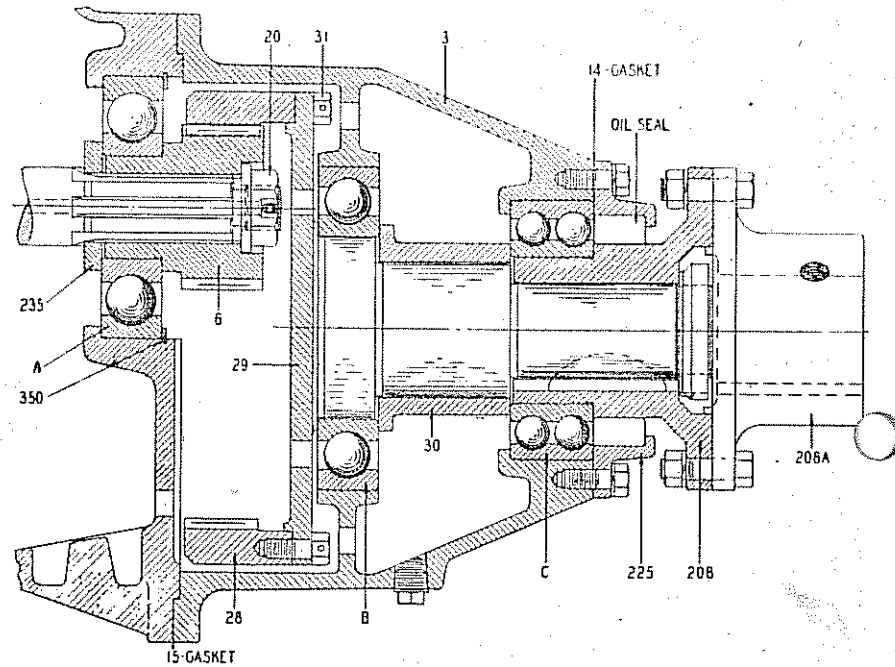

Numbers shown are key numbers only.  
Refer to parts list for complete part number.

Part No.	No. Reqd.	Name
<b>REVERSE GEAR—REDUCTION DRIVE—(2xE-90) (Spec. Z-5477)—(Continued)</b>		
3XE-433	1	Brake Reverse Yoke Ball Joint
3XE-434	1	Brake Reverse Yoke Ball Joint Screw
3XE-435	1	Brake Short Toggle Lever Pin
3XE-436	1	Brake Band Brace Screw

**REDUCTION GEAR—KLR—(Spec. Y-5286)**

**RA20—2 to 1—SINGLE STAGE**

RA20-3F	1	Reduction Gear Housing—(Snap Ring Style)
RA20-15	1	Reduction Gear Housing Gasket
RA20-6	1	Main Drive Pinion
RA20-0-6	1	Driving Pinion Gear (opp. Rotation) after eng. 23782
RA20-28	1	Internal Ring Gear
RA20-0-28	1	Internal Ring Gear (Opp. Rotation) after Engine No. 23782
RA20-29	1	Internal Ring Gear Flange
RA20-31	8	Internal Ring Gear Flange Screw
RA20-235	1	Ball Bearing Thrust Washer
3172	1	Ball Bearing—Front—407-W (Key No. A)
3168	1	Ball Bearing—Center—310-W (Key No. B)
3170	1	Ball Bearing—Rear—5211-G (Key No. C)
RA20-350	1	Front Ball Bearing Retainer Ring
RDAA-20	1	Driving Pinion Nut
RA20-30	1	Ball Bearing Spacer
RA20-225	1	Rear Ball Bearing Oil Seal Retainer
RA20-14	1	Rear Ball Bearing Oil Seal Retainer Gasket
3186	1	Rear Ball Bearing Oil Seal
RA20-208	1	Propeller Shaft Coupling—Gear Half
RA20-208A	1	Propeller Shaft Coupling—Shaft Half—(2317—1¼") (2318—1⅜")
2279	1	Reverse Gear Housing.

**REDUCTION GEAR—KLS—(Spec. Y-5302)**

**RA-15—1½ to 1—SINGLE STAGE**

RA20-3F	1	Reduction Gear Housing—(Snap Ring Style)
RA20-15	1	Reduction Gear Housing Gasket
RA-15-6A	1	Main Drive Pinion
RA15-0-6A	1	Main Drive Pinion—Opposite—After Eng. No. 23831
RA20-28	1	Internal Ring Gear
RA20-0-28	1	Internal Ring Gear—Opposite—After Eng. No. 23831
RA20-29	1	Internal Ring Gear Flange
RA20-31	8	Internal Ring Gear Flange Screw
RA20-235	1	Ball Bearing Thrust Washer
3172	1	Ball Bearing—Front—407-W (Key No. A)
3168	1	Ball Bearing—Center—310-W (Key No. B)
3170	1	Ball Bearing—Rear—5211-G (Key No. C)
RA20-350	1	Front Ball Bearing Retainer Ring
RDAA-20	1	Driving Pinion Nut
RA20-30	1	Ball Bearing Spacer
RA20-225	1	Rear Ball Bearing Oil Seal Retainer
RA20-14	1	Rear Ball Bearing Oil Seal Retainer Gasket
3186	1	Rear Ball Bearing Oil Seal
RA20-208	1	Propeller Shaft Coupling—Gear Half
RA20-208A	1	Propeller Shaft Coupling—Shaft Half—(2317—1¼") (2318—1⅜")
2449	1	Reverse Gear Housing